



**R-VRF 6  
Outdoor Unit**

Before installing the unit, please read this manual carefully.  
RICOS has the right to make changes to the design without prior notice.

**Safety precautions**

In order to prevent the risk of death, serious injury or damage to property please comply with the following important safety instructions.

The extent of possible harm is described by the following symbols.

<b>WARNING</b>
This symbol indicates danger of death or serious injury.







<b>CAUTION</b>
This symbol indicates danger of death or damage to property.

The unit must be operated in accordance with the following symbols.



















This symbol indicates something which is strictly forbidden.

This symbol indicates something which must be adhered to.

**Protective measure**

<b>WARNING</b>	
<p>1. Your air conditioner is not designed to be installed by yourself and should only be installed by a qualified, competent and trained technician. The presence of Mains Voltage electricity and high pressure refrigerant gas make installing this system a specialist task which you should not attempt yourself. </p> <p>2. Any electrical work on the air conditioner should only be carried out by a qualified, competent and trained technician and not by yourself.</p> <p>3. Ensure the electrical power is disconnected during service and maintenance.</p>	
<b>IMPORTANT</b>	
<ul style="list-style-type: none"> <li>This unit is not suitable for operation by minors or disabled users.</li> <li>Children should be prevented from operating the air conditioner.</li> </ul>	
<b>WARNING</b>	
<ul style="list-style-type: none"> <li>This unit must be correctly earthed. Incorrect grounding will cause earth leakage and electric shock.  </li> </ul>	<ul style="list-style-type: none"> <li>Earth Leakage Protection must be installed. Failure to do so carries the risk of electric shock and fire. </li> </ul>
<b>CAUTION</b>	
<ul style="list-style-type: none"> <li>Do not install either the indoor or outdoor unit in a place where flammable or explosive gases are present or there is a high risk of a fire or explosion occurring. </li> </ul>	<ul style="list-style-type: none"> <li>Ensure the unit drain pipe work is properly connected and made or water leaks will occur. </li> </ul>

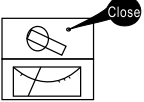
**Safety precautions**



<b>WARNING</b>		
Don't use flammable sprays near the air conditioner.		If there are some abnormalities (such as the smell of scorching), please shut down and cut off power supply. 
Don't use open flame near the air conditioner.		Don't use sub-standard or damaged wires.  
Don't attempt to repair the air conditioner yourself.		Don't put fingers or other objects into the air conditioner. Don't touch metal parts of the heat exchanger. 
<b>CAUTION</b>		
Your air conditioner is designed for comfort cooling or heating. It is not designed for any other purpose and specifically should not be used for storing food, animals, plants, precision instruments, art or antiques, nor any other special item. It is not designed for specialist computer rooms.  		Do not use naked flames where the air flow from the unit can reach directly. The air from the unit will interrupt the combustion process and either extinguish the flame or misdirect it. Either is a danger of fire or explosion. 
Your air conditioner contains water and may also drip if the humidity of the room is too high. Do not, therefore, place any object under the unit which could be damaged in the event of water dripping on it. 		Do not direct the air from the unit directly onto animals or plants as this may be harmful to them. 
Do not sit in the cold air stream directly for long periods. 		Ensure the room properly ventilated. 
Check the air conditioner regularly to ensure correct operation and that nothing has become loose. 	Do not clean the air-conditioner with water. 	Before cleaning the air conditioner, cut off the power.  

**Installation precautions**

- Before commencing with the installation please read these installation precautions thoroughly, making sure you understand them in full.
- These installation precautions are very important for safety of you and others and should be complied with in full.
- The potential risks are described by the following symbols.

<b>WARNING</b>	Danger of serious injury or death.
<b>CAUTION</b>	Danger of damage to property.
<b>FORBIDDEN</b>	Do not do this under any circumstances.

- The below symbols indicate steps which are mandatory.

 	These steps are mandatory and should be carried out without fail.
---	---

- It is important that the unit is correctly commissioned after the installation is complete to ensure it is operating correctly.

After commissioning you should use this manual explain to the user the correct method of operating the unit and its maintenance requirements.

### **WARNING**

- Do not attempt to install this unit yourself. Incorrect installation can cause refrigerant or water leakage, electric shock, fire or other to health and safety or property.
- Where the unit is installed must be solid enough to withstand the weight of the unit. If it is not, then there is the danger of the structure collapsing or the unit falling creating a danger of serious injury or death.
- The installation should be mindful of potential damage by strong winds, earthquakes or other natural phenomena. These should not be able to cause the unit to fall over and cause an accident.
- The electrical installation should be in accordance with local and national specifications and only be carried out by qualified personnel in accordance with installation instructions. The air conditioner should have its own dedicated power supply.
- Ensure the power supply is of sufficient capacity for the unit or there is a risk of fire, electric shock or other failure.
- The wiring should be made correctly using the specified cable and properly secured to avoid the risk of external forces causing the connections to come loose. Failure to come loose.
- Failure to de this runs the risk of electric shock or fire. Ensure the refrigerant pipe work is fully evacuated and leak tested and do not over charge with refrigerant. Over charging with refrigerant can cause a leak to occur after installation. Leaks can cause a high concentration of refrigerant in an area which may result in sudden death by asphyxiation.
- Do not carry out any electrical work unless the power supply has been disconnected. If the unit is installed in a small room, there is danger of a leak causing the refrigerant gas concentration to exceed the maximum permissible for safe breathing and this can cause sudden death by asphyxiation. Please consult your dealer about preventative measures such as audible visual leak detectors.
- When making pipe connections be sure to use a torque wrench and tighten the flare nuts to the correct torque. Over and under tightened nuts can cause refrigerant gas to leak. Do not operate the compressor unit the pipe work has been correctly made, leak tested and evacuated.
- While performing installation or maintenance ensure that no foreign objects can enter the either the unit or pipe work.

**WARNING**

- Do not use any refrigerant other than the one indicated on the outdoor unit name plate. Do not allow foreign bodies or moisture to enter the pipe work during installation and ensure the pipe work is fully leak tested and evacuated before running the unit. If the refrigerant gas becomes contaminated with moisture, air or other gases then unit will not perform correctly and there is a risk of leakage, explosion or other damage to the unit.
- Do not extend the power cable to use multiple power cables.
- Do not place the outdoor unit near balconies or anywhere children can climb onto it and potentially fall off and injure themselves.
- If there is a refrigerant leak during installation immediately ventilate the space thoroughly. Once the installation is complete carry out a thorough leak test of system.
- Never allow refrigerant gas to make contact with sparks or naked flames and during refrigerant releases poisonous gases. Ensure the electrical supply cable is properly protected and connections are made properly. Bad connections will cause the cable to overheat and potentially cause electric shocks or fire.
- An Earth leakage protector must be installed. The entire electrical installation should be checked by a qualified electrician to avoid the potential for electrical shocks or fire. The unit must be adequately earthed.
- Never connection the earth wire to gas or water pipes, lighting rods or telephone cables. Inadequate grounding of the earth cable may lead to the danger of serious injury or death by electric shock.
- This appliance can be used by children aged from 8 years and above and persons with reduced physical, sensory or mental capabilities or lack of experience and knowledge if they have been given supervision or instruction concerning use of the appliance in a safe way and understand the hazards involved. Children shall not play with the appliance. Cleaning and user maintenance shall not be made by children without supervision. (Only for the AC with CE-MARKING).
- This appliance is not intended for use by persons (including children) with reduced physical, sensory or mental capabilities, or lack of experience and knowledge, unless they have been given supervision or instruction concerning use of the appliance that they do not play with the appliance. (Except for the AC with CE-MARKING).
- For 8HP, 10HP and 12HP  
This equipment complies with EN 61000-3-12:2011 provided that the short-circuit power  $S_{sc}$  is greater than or equal to 5116.478 kVA at the interface point between the user's supply and the public system. It is the responsibility of the installer or user of the equipment to ensure, by consultation with the distribution network operator if necessary, that the equipment is connected only to a supply with a short-circuit power  $S_{sc}$  greater than or equal to 5116.478 kVA.
- For 14HP and 16HP  
This equipment complies with EN 61000-3-12:2011 provided that the short-circuit power  $S_{sc}$  is greater than or equal to 7420.106 kVA at the interface point between the user's supply and the public system. It is the responsibility of the installer or user of the equipment to ensure, by consultation with the distribution network operator if necessary, that the equipment is connected only to a supply with a short-circuit power  $S_{sc}$  greater than or equal to 7420.106 kVA.
- For 18HP, 20HP and 22HP  
This equipment complies with EN 61000-3-12:2011 provided that the short-circuit power  $S_{sc}$  is greater than or equal to 9844.977 kVA at the interface point between the user's supply and the public system. It is the responsibility of the installer or user of the equipment to ensure, by consultation with the distribution network operator if necessary, that the equipment is connected only to a supply with a short-circuit power  $S_{sc}$  greater than or equal to 9844.977 kVA.

### CAUTION

- Ensure the drain pipe is installed in accordance with the installation instructions and adequately insulated to protect against condensation forming. Badly installed drain pipe work can cause expensive damage due to water leaks.
- Your air conditioner contains sophisticated electronic controls which may be subject to interference from radios, television, mobile telephones or other electronic goods. Do not operate these items near air conditioner or they may cause the unit to fail. We suggest maintaining a distance from these items to indoor unit at least 1 meter and to the outdoor unit of at least 2 meter. Depending upon the type and frequency of the electromagnetic signal you may need to leave a longer distance than this.

### FORBIDDEN

- Do not try and install, service or remove the air conditioner yourself. Contact the dealer or service center.
- Do not mount this system in a vehicle, ship, aircraft or other place which will move while the unit is in operation.
- Do not install this unit where there will flammable or explosive gases present. If these leak and accumulate near the air conditioner than a fire or explosion may result.

All Parts' Name and Role

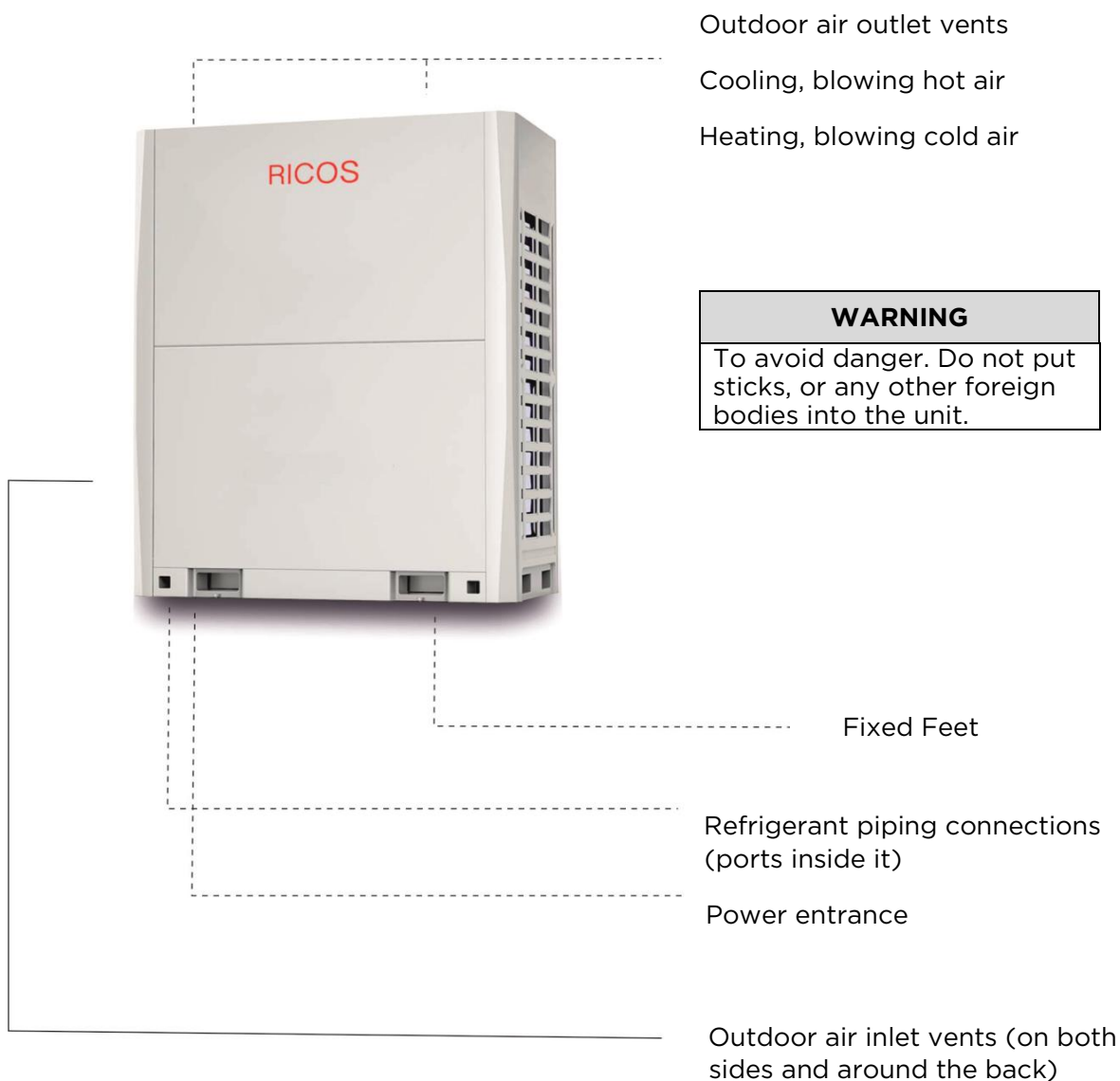



**WARNING**  
To avoid danger. Do not put sticks, or any other foreign bodies into the unit.

**Note**

- Air conditioning only can be worked after power switch be opened more than 12 hours. In addition, please do not cut off the power supply, when that is a short period of time around day and night stands. (This is to heat the compressor, avoided the compressor starting with liquid).
- Be careful not to plug air inlet and outlet vents. Otherwise, air conditioner may be a degradation performance or automatically start-up the protection fixture to stop running.

## Installation Notes

### Installation Sites

<b>Note</b>	<b>Installation Sites Confirmed</b> 	Do not install in the place where flammable gas can be easily leaked. Once flammable gas leaks and strands around the outdoor unit, it may trigger fires.
	<b>Fixation Confirmed</b> 	Confirm the base whether firmly installed. If the foundation is not solid, outdoor machines may fall down and transform an accident.



### Request

- Please avoid closing with high frequency facilities.
- Avoid installing in the following places: the place with much oil (including engine oil) foam or stream, including the areas with much sea salt, including the place has many sulfides hot springs. It is easy to occur accidents in these places.
- Please contact dealers if it will be installed under a special requirement.
- The air inlets of outdoor unit should have a open around to be sure it has a well-ventilation.
- Avoid the strong winds blowing the inlet and outlet vent directly.
- In the snow region, should be installed a shelf for the outdoor unit to anti-snow or anti-ice. More details please contact the dealer advisory.

### Attention to the operative noise

- Do not choose the place where may spread the noise more louder.
- The noise level will increase when there has obstructions near by the outdoor unit.
- Choose a right place, avoid outdoor unit's hot or cold wind blowing to your neighbors and avoid the machine's noise be an inconvenience to them.

<b>WARNING</b>	<b>Confirmed grounding</b> 	Confirm whether the correct grounding. It will cause an electrocution if there has an imperfect grounding.
----------------	---	--

<b>Note</b>	<b>Leakage circuit protection confirmed</b> 	Confirm whether have installed the leakage protection switch. The leakage protection switch must be installed. Otherwise it may cause electrocution.
	<b>Correct fuse confirmed</b> 	Do not use the fuse that do not have the appropriate capacity. It is possible to cause a failure or causing electrocution if using the copper wire or ferric wire.



## Operation and Performance

### About Three-minute Protection

- It should take about three minutes to restart the unit after stop running or re-run the unit with manual switch. This is the self-protection of the compressor.

### Cooling&Heating

- Indoor unit of DC inverter scroll central air-conditioning can be individually controlled, but the same system's outdoor unit can't be cooling or heating at the same time.
- When it has conflict between cooling and heating type, mainly considered that mode which is opening at present, to other contrary mode make panel flashing, one indoor unit stop running, the other working indoor AC keep running as usual.

### Heating Characteristics

- Operation will not be immediately at the start of hot air blowing, after around 3-5 minutes (delay or forward according to the temperature around) it will blowing hot air when indoor heat exchanger be heat enough.
- The outdoor's fan motor might cease when there's a high outdoor temperature.
- During the air supply operation, if the other indoor units on a heating model, it is possible to suspend air supply in order to prevent hot air blowing.

### Defrost In Heating Mode

- On heating model, outdoor machines occur the frost phenomenon, in order to improve the heating effect, automatic running defrost operation (about 2-10 minutes), the drainage vent from the outdoor unit.
- On the defrosting mode, the outdoor fan motor stop running, indoor units also stop the fan motor running.

### Running Conditions

For the proper use, running in the following conditions.

<b>Cooling</b>	Outdoor air temperature	-5 °C - 52 °C (-5 °C - 55 °C)
	Room temperature	21 °C - 32 °C
	Room humidity	≤80 % Humidity over 80 % and long-term running, it may have condensate water on the surface or blow the mist cooking air around the outlet.
<b>Heating</b>	Outdoor air temperature	-25 °C - 24 °C (-15 °C - 24 °C) (-20 °C - 24 °C)
	Room temperature	≤28 °C

Once running another conditions which did not in the above-mentioned, it will activate protective device operation and stop running. **(Different types of heating adapt to different outdoor working conditions.)**

### Protection Device (High Voltage Switch)

This device terminate running automatically during a compulsory working. Protection device moves circumstances, stop running, and show the trouble code.

In the event of the following circumstances, the protection of installations is activated.

#### Cooling

- Outdoor Unit's inlet or outlet was full of plug.
- Sustained strong winds blow to the outdoor unit's tuyere.

#### Heating

- Indoor unit's filter conglutinate too much excessive dust and litter.
- Indoor unit's outlet has been obturated.

When protection device actions, please manually cut off the power switch, do not restart it till founded the reasons.

### The Power Cut

- If there's power cut during the running, then there will be a cessation of all operations.
- Restart it after the power cut, the indicator of wired controller will flicker for a notice.
- When re-start again, please press re-operation/stop button.

### Mulfunction Happens During Operation

If malfunction happens during operation because of the thunder and lightning, the automobile radio and so on, please do shut off the manual power switch, after electrifying again, then press re-operation/stop button.

### Heating Capacity

- The system is absorbing heat from the outside, and releasing them to the indoor, once the outdoor temperature become lower, then the heating capacity will be lower.
- Proposed use other heating equipments together when outdoor temperature is too low.
- In the alpine areas where has a particularly low temperature, the heating effect will be even better if the indoor unit has auxiliary electric heating device.

(Please read the detailed from Indoor Unit Manual)

**Abnormal Situation**

Before you declare the maintenance services, please refer to the following table when there's event of the following situations.

	Phenomenon	Reasons
It's not Failure	Outdoor Unit • White mist or water appeared. • Make a sound of "Pu-pu" every now and then.	<ul style="list-style-type: none"> <li>• Outdoor's fan motor stop defrosting automatically.</li> <li>• The electro-valve make the sound at the beginning and the ending of the defrost progress.</li> <li>• There occur a voice alike stream during or ending the working. The voice will be more louder after 3-15 minutes, that is the voice of refrigerant flowing or the voice of dehumidification water's drainage.</li> <li>• There is a "Pu-pu" minor voice during its working, cause the reason of temperature changes, heat exchangers minor expand and make that voice.</li> <li>• The dust from walls, carpets, furniture, clothing, cigarettes and cosmetics attached to the air-conditioning.</li> <li>• Restart the unit after a power cut though the manual power switch, lights flashing.</li> <li>• As a multi-units used, the lights flash and it stop running in the following situations.                             <ol style="list-style-type: none"> <li>(1) Do not cooling cause the other indoor machines' infection.</li> <li>(2) When there's a antinomy between the model has been set and the model fixed.</li> <li>(3) Stop blowing to prevent the cooling wind blowing out.</li> </ol> </li> </ul>
	Indoor Unit • The wind has peculiar smell. • Running lights flashing. • "Cooling" or "heating" lights flashing on the operation panel.	
Please Check It Once More	<ul style="list-style-type: none"> <li>• Run or stop automatically</li> </ul>	<ul style="list-style-type: none"> <li>• Whether the timer be mis-operated.</li> </ul>
	<ul style="list-style-type: none"> <li>• Not running</li> </ul>	<ul style="list-style-type: none"> <li>• Whether power cut</li> <li>• Manual power switch turn off or turn on.</li> <li>• Whether the fuse be cut.</li> <li>• Whether the protection device work or not (Fault Code)</li> <li>• Whether the timer has reach the ordered time (running lights flashing)</li> </ul>
	<ul style="list-style-type: none"> <li>• Poor effect of heating or cooling</li> </ul>	<ul style="list-style-type: none"> <li>• Whether the outdoor unit's outlet or inlet has been blocked.</li> <li>• Whether doors and windows open.</li> <li>• Whether the filter has full of dust and garbage blocking.</li> <li>• Whether that is a appropriate position for the wind guide bar.</li> <li>• Whether the wind switching model is "blow".</li> <li>• Whether it is appropriate temperature setting.</li> <li>• Whether the indoor's operation mode is assort with other indoor units.</li> </ul>

Following situations should be stopped running immediately, cutting off power switch manually, and distributors to contact.

- Switch action inaccurate.
- Fuses or leakage protection frequently cut.
- Misuse foreign bodies or water enter into the air-conditioning.

## Installation Instructions

### Some Items Should Be Taken Before Reading The Installation Manual

- This installation manual applies for the outdoor unit.
- When installing the indoor unit, please refer to the installation manual for indoor unit.

### Key Points

#### Key Points Of Inspection When Installing

#### Installation

Recognized model, name, to avoid mistakes when installing.

#### Refrigerant Piping

- Refrigerant piping should be used together with the specific (optional) refrigerant distributor. (Ramification joints, ramification header).
- Refrigerant piping should take the pipes with the designated diameter.
- Nitrogen gas with the certain pressure should be charged to the refrigerant piping before welding.
- Insulation for the refrigerant piping should be taken.
- When the installation for the refrigerant piping is finished, the indoor unit should power off before the airtight experiment and vacuumize. Airtight experiment and vacuumize should be taken respectively for the gas side and liquid side.

#### Leakage Testing

- Refrigerant piping must take the airtight experiment [nitrogen gas with the pressure of 4.2 Mpa (43Kgf/cm<sup>2</sup>)].

#### Vacuumize

- Vacuum pumps must be used when vacuumizing for connecting piping, and both gas side and liquid side should take at the same time.

#### Refrigerant Supplementary

- When exceeding the refrigerant supplementary for benchmark piping length, is should take the formula in case of the piping length (real length) to find the additional volume of each system.
- Take down the refrigerant supplementary, piping length (real length) and the height differences between indoor unit and outdoor unit on the sevice table for outdoor unit (lelctronic control box), in case of uses.
- The unit has automatic perfusion function, after debugging, the detailed operation is contained in the content of “refrigerant filling” module.

#### Electrical Wiring

- Power capacity, the choice of wire diameter, based on the design manual. Air conditioning power line is bigger than General Motor Power Line.
- To prevent the mis-actions of air conditioners, must take care not to let power line (380 V 3N - ) and the indoor and outdoor connectivity wiring (low-voltage wiring) staggered, winding.
- Indoor unit should power on after the airtight experiment and vacuumize.

- Address for the outdoor unit must be set, detailed in the “address for outdoor unit code”.

### Trial Operation

- Trial operation can be taken after the Outdoor unit is powered on for more than 6 hours.

## Installation Sites

### Attention

1. Avoid installation in the following sites:
  - Areas with Combustible Gas-leak Areas with oil.
  - Areas with High salt content (coastal area).
  - Area with sour gas. (Hot Springs area)

(Once in the use of these special places, the air conditioning will be a failure, so be sure to observe the use of air-conditioned places requirements).

- The sites that noise of outdoor unit impacts the normal life of local people.
  - The sites that not be able to sustain the weight of outdoor unit.
  - The sites that not with the same horizontal level.
  - The sites that the ventilation is poor.
  - The sites with a private power generation equipment and high-frequency.
  - The sites with strong electromagnetic interferences.
2. Metal part of the building and the grounding metal part of the air-conditioning, please refer to the national electrical standards implementation.

### Attention to the operative noise

- Do not choose the place where may spread the noise more louder.
- The noise level will increase when there has obstructions near by the outdoor unit.
- Choose a right place, avoid outdoor unit's hot or cold wind blowing to your neighbors and avoid the machine's noise be an inconvenience to them.

### The Transit For Outdoor Unit

1. Steel wire can be used for transit:
  - Please use four pieces of steel wires with the diameter more than 6 mm to hang the outdoor unit, take care of the barycenter, in case of sliding and dumping.
  - To avoid the surface injury and deformation, please use protect boards between the contact point of the steel wire and the air conditioner.
  - When transit finishes, please take off the transportation plate.
2. Using forklifts to transit.

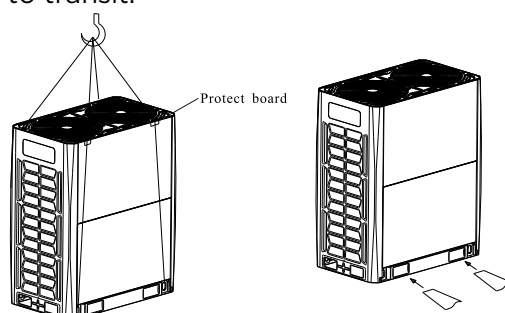

## Mounting Space

1. When installing, set aside the maintenance space as shown the following diagram; installing the outdoor unit, power equipment should install at the side of outdoor unit, as to the installation method please refer to the power equipment installation manuals.
2. Please ensure the necessary space for maintenance, and the modules within the same system must be placed at the same level. (see blow)

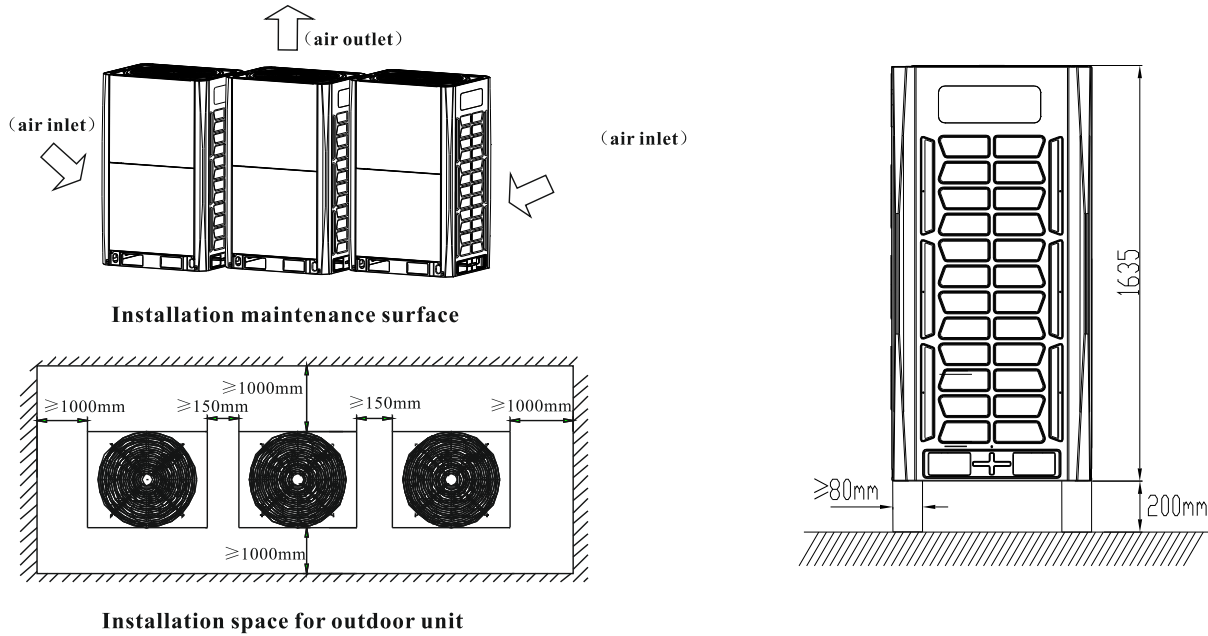

3. The installation space for anchor bolt please refer to the following drawing.

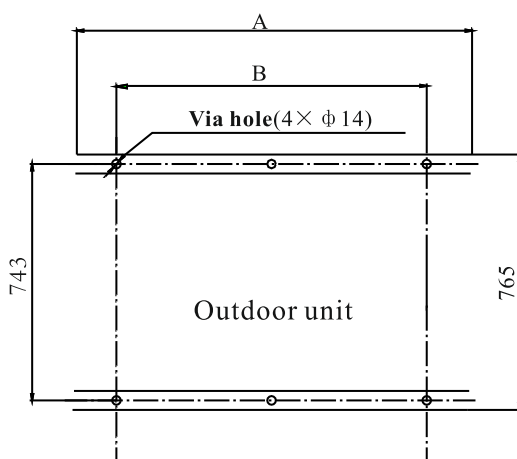

	A	B
8 HP-12 HP	990	730
14 HP-22 HP	1340	1085

T3 model:

	A	B
8 HP-10 HP	990	730
12 HP-16 HP	1340	1085

4. When there is the barrier above the outdoor unit.

A>45°

B>300 mm

C>1000 mm

D Guide vane

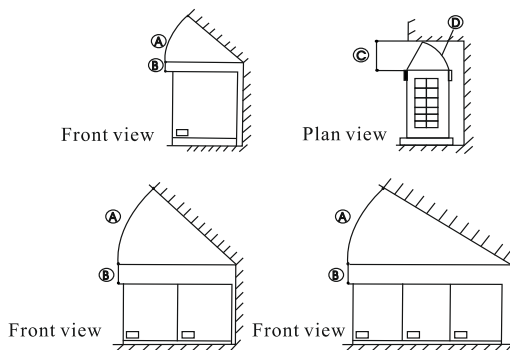

**Note:** If there are piling stuff around the outdoor unit, then the height from the head of outdoor unit should more than 800 mm. If the size is less than above-mentioned requirements, then need to increase mechanical exhaust devices.

**Outdoor Unit Installation**

As to the snowfall area, it is necessary to install anti-snow facilities. (see below) (anti-snow facilities incomplete, the fault-prone).To avoid the infection of the snow, elevated-lift, install the anti-snow shelf at the site of air inlet and outlet.

**Refrigerant Piping**

1. The joints of refrigerant piping are the internal side of ODU, so please remove the under pull first.
2. Piping can remove from the baseboard of outdoor unit or low left conner square hole.
3. When connecting, first pass the L-type pipe through the base plate, and the square hole of the crossbeam leads to the left, then to the left, to the right or backward to install the refrigerant ramification.

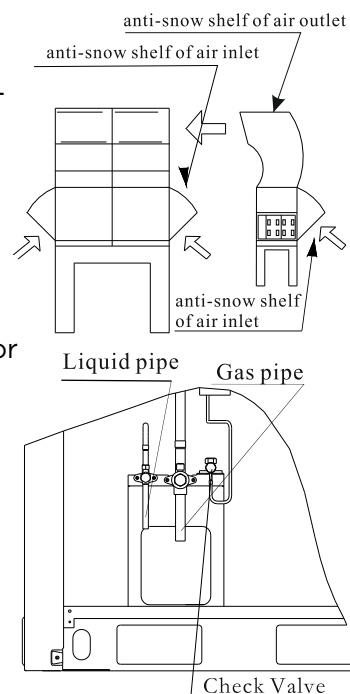

**Notes**

In order to prevent internal piping nitride, nitrogen filling operations must be taken when the piping is welding, otherwise oxidation chip will plug the refrigeration cycling.

**The Panel of Outdoor Unit Installation**

- While removing the panel 1 for the first time, we need take out the EPE cotton 2 on the bottom and loosen screws 2. Pat the panel or insert a screwdriver to the gap between the panels 4, pry down the panel gently. Please prevent the panel from slipping, as shown in Figure 1.
- While assembling the lower panel, we should lean the hemline of the lower panel on base beam, then adjust the panel against to the side plates, lift the panel up from both bottom sides, as shown in Figure 3.
- The instructions for pipeline connection and the location of the electric box are respectively shown in Figure 2 and figure 4.

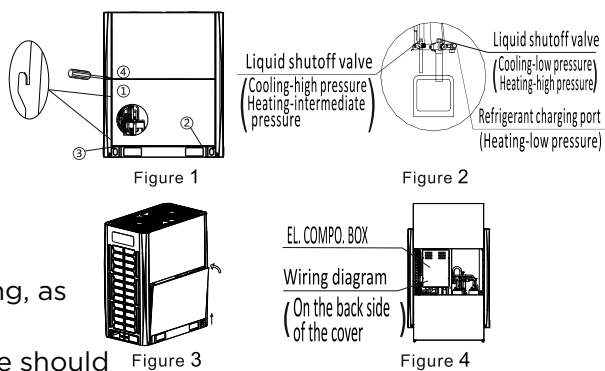

**Outdoor Unit Combination**

Type (HP)	Ways of combinations	Type (HP)	Ways of combinations	Type (HP)	Ways of combinations	Type (HP)	Ways of combinations
8	8*1	30	10+20	52	10+20+22	74	10+20+22+22
10	10*1	32	10+22	54	10+22+22	76	10+22+22+22
12	12*1	34	12+22	56	12+22+22	78	12+22+22+22
14	14*1	36	14+22	58	14+22+22	80	14+22+22+22
16	16*1	38	16+22	60	16+22+22	82	16+22+22+22
18	18*1	40	18+22	62	18+22+22	84	18+22+22+22
20	20*1	42	20+22	64	20+22+22	86	20+22+22+22
22	22*1	44	22+22	66	22+22+22	88	22+22+22+22
24	12+12	46	12+12+22	68	12+12+22+22		
26	10+16	48	10+16+22	70	10+16+22+22		
28	12+16	50	12+16+22	72	12+16+22+22		

**T3 model:**

Type (HP)	Ways of combinations	Type (HP)	Ways of combinations	Type (HP)	Ways of combinations
8	8*1	28	12+16	48	16+16+16
10	10*1	30	14+16	50	8+10+16+16
12	12*1	32	16+16	52	10+10+16+16
14	14*1	34	8+10+16	54	10+12+16+16
16	16*1	36	10+10+16	56	12+12+16+16
18	8+10	38	10+12+16	58	10+16+16+16
20	10+10	40	12+12+16	60	12+16+16+16
22	10+12	42	10+16+16	62	14+16+16+16
24	12+12	44	12+16+16	64	16+16+16+16
26	10+16	46	14+16+16		

**Piping Size And Connection Method**

Table 1: Pipe category

Name of piping	Piping connecting position	As the following coding
Main tube	The pipes between outdoor unit and the first ramification pipe of indoor unit	1
Main piping	The pipes after the ramification pipe, indirectly connect with the indoor unit	2
Branch piping	The pipes after the ramification pipe and directly connect with the indoor unit	3



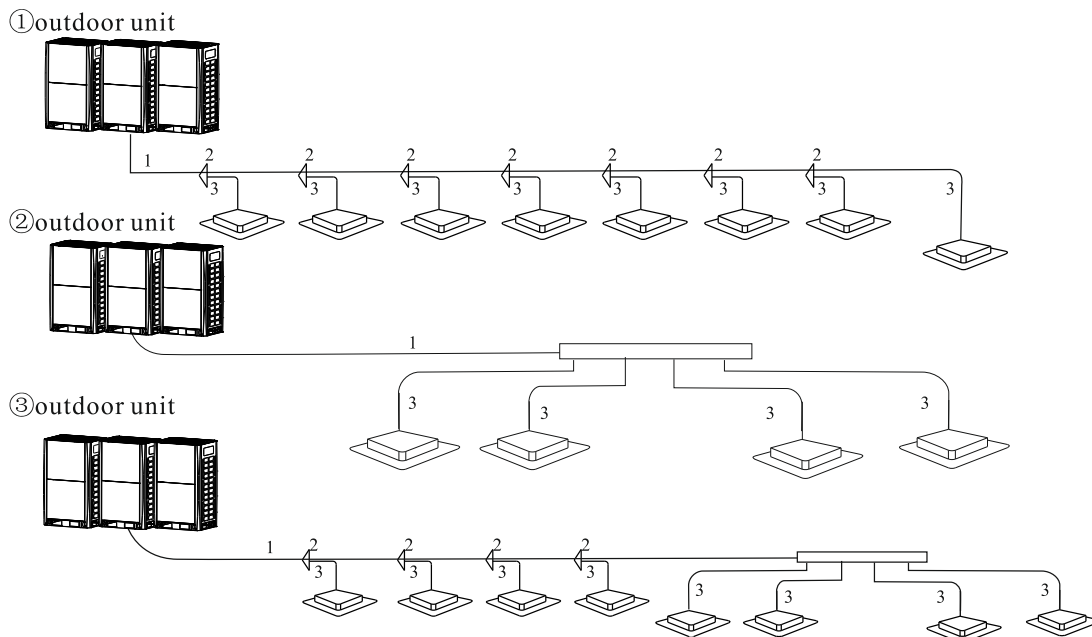

**Sketch of module installation**

Diameter of piping 1 depends on the total capacity of outdoor unit connected to the branch pipe.

Total capacity of outdoor unit (HP)	Diameter of main tube (outdoor unit to 1 <sup>st</sup> branch) < 90 m		Diameter of main tube (outdoor unit to 1 <sup>st</sup> branch) ≥ 90 m	
	Gas side/Liquid side	The 1 <sup>st</sup> branch pipe	Gas side/Liquid side	The 1 <sup>st</sup> branch pipe
8	Φ22.2/Φ12.7	RF-12B	Φ22.2/Φ12.7	RF-12A
10			Φ25.4/Φ12.7	RF-24A
12			Φ28.6/Φ15.88	RF-24A
14	Φ28.6/Φ15.88	RF-24B	Φ28.6/Φ15.88	RF-24A
16			Φ31.8/Φ15.88	RF-34A
18-22	Φ28.6/Φ15.88	RF-24B	Φ31.8/Φ19.05	RF-34A
24-34	Φ31.8/Φ19.05	RF-34B	Φ38.1/Φ22.2	RF-50A
36-48	Φ38.1/Φ19.05	RF-50B	Φ41.3/Φ22.2	RF-50A
50-66	Φ41.3/Φ22.2	RF-50B	Φ44.5/Φ25.4	RF-64A
68-88	Φ44.5/Φ25.4	RF-64B	Φ47.6/Φ25.4	RF-64A

**T3 model:**

Total capacity of outdoor unit (HP)	Diameter of main tube (outdoor unit to 1 <sup>st</sup> branch) < 90 m		Diameter of main tube (outdoor unit to 1 <sup>st</sup> branch) ≥ 90 m	
	Gas side/Liquid side	The 1 <sup>st</sup> branch pipe	Gas side/Liquid side	The 1 <sup>st</sup> branch pipe
8	Φ22.2/Φ12.7	RF-12B	Φ22.2/Φ12.7	RF-12A
10			Φ25.4/Φ12.7	RF-24A
12			Φ28.6/Φ15.88	RF-24A
14	Φ28.6/Φ15.88	RF-24B	Φ31.8/Φ15.88	RF-34A
16			Φ31.8/Φ19.05	RF-34A
18-22			Φ31.8/Φ19.05	RF-34A
24-34	Φ31.8/Φ19.05	RF-34B	Φ38.1/Φ22.2	RF-50A
36-48	Φ38.1/Φ19.05	RF-50B	Φ41.3/Φ22.2	RF-50A
50-66	Φ41.3/Φ22.2	RF-50B	Φ44.5/Φ25.4	RF-64A

**Notice:**

## RICOS R-VRF 6 Outdoor Unit

---

- 1) All piping refers to the sum of gas pipe equivalent length and liquid pipe equivalent length in the table.
- 2) Diameter of main tube depends on the 1<sup>st</sup> branch pipe of outdoor unit when the total capacity of indoor is larger than the total capacity of outdoor unit.
- 3) Y type branch pipe is priority selection, and U type branch pipe and comb type are selected on special occasion. T type branch pipe is forbidden to use. All branch pipes must be installed horizontally 1.
- 4) Size of single module 12 HP's liquid piping is  $\Phi 12.7$ , which is not accordance with the size of main tube ( $\Phi 15.88$ ). Then the liquid piping should be connected with the main tube through an adjustable tube which its tube size turns from  $\Phi 12.7$  to  $\Phi 15.88$ .
- 5) When the outdoor capacity reaches 50–66 HP, size of gas branch piping is  $\Phi 38.1$ , which is not accordance with the size of main tube ( $\Phi 41.3$ ). Then the gas branch piping should be connected with the main tube through an adjustable tube which its tube size turns from  $\Phi 38.1$  to  $\Phi 41.3$ .
- 6) When the outdoor capacity reaches 68–88 HP, size of gas&liquid branch piping are  $\Phi 47.6$ & $\Phi 22.2$ , which is not accordance with the main tube ( $\Phi 44.5$ & $\Phi 25.4$ ). Then the gas&liquid branch piping should be connected with the main tube through adjustable tubes which theirs tube size turns from  $\Phi 47.6$  to  $\Phi 44.5$  and from  $\Phi 22.2$  to  $\Phi 25.4$ .

- **One module**

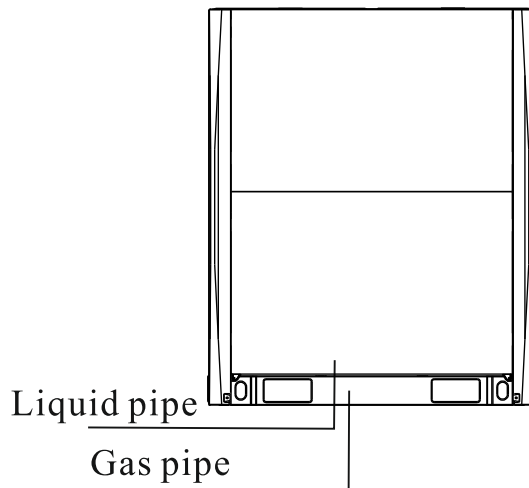

**Note:**

The size for 8 HP, 10HP, 12 HP piping liquid side  $\Phi 12.7$ , gas side  $\Phi 22.2$ ; **(Some T3 models are excluded).**

The size for 14 HP, 16 HP, 18 HP, 20 HP, 22 HP piping liquid side  $\Phi 15.88$ , gas side  $\Phi 28.6$ .

- **Two modules combination**

(1) 24 HP - 34 HP

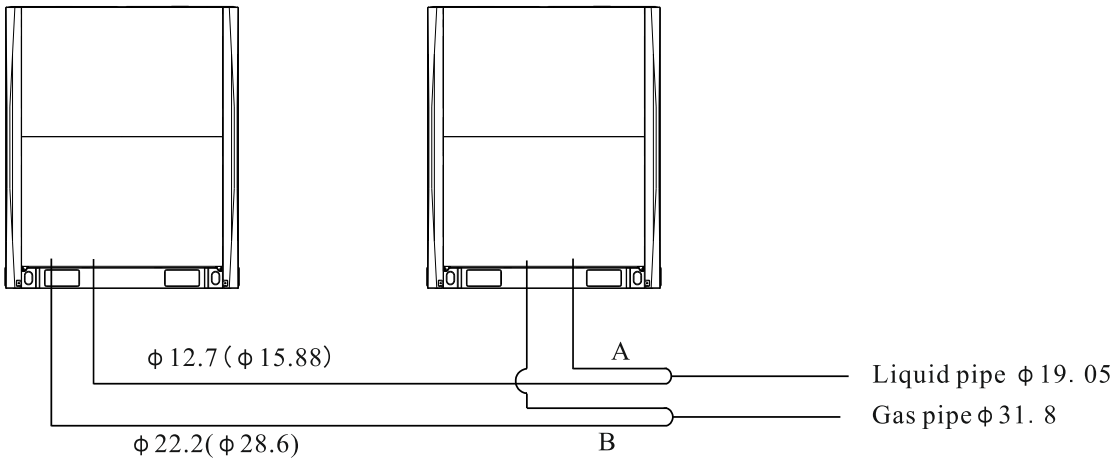

**Note:**

The sketch drawing for size A of liquid side Y shape three way valves as following:

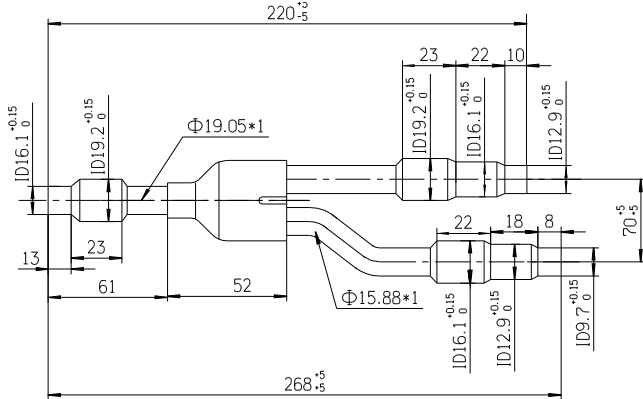

The sketch drawing for size B of gas side Y shape three way valves as follows:

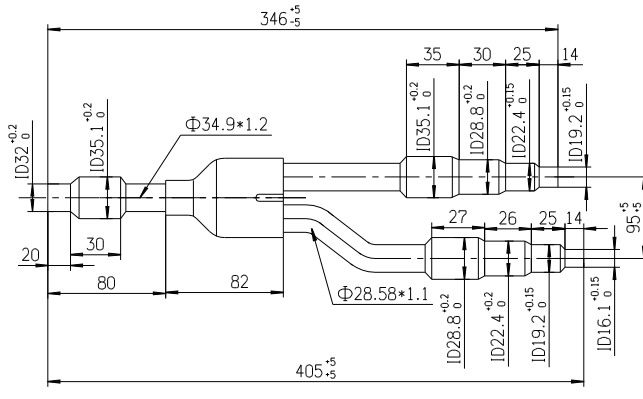

# RICOS R-VRF 6 Outdoor Unit

The model of gas side and liquid side Y shape three-way valve is RF-34B.

36 HP - 44 HP

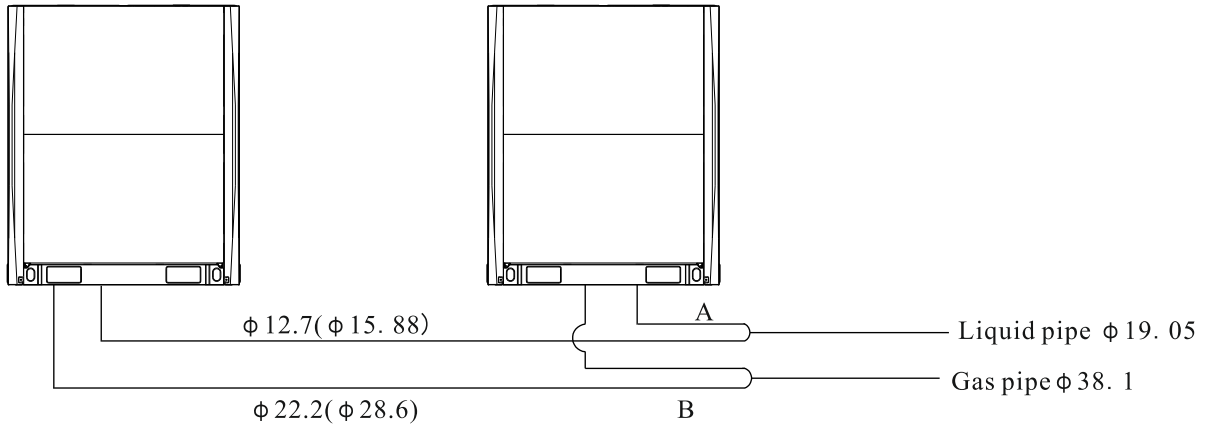

**Note:**

The sketch drawing for size of liquid side Y shape three-way valve A as follows:

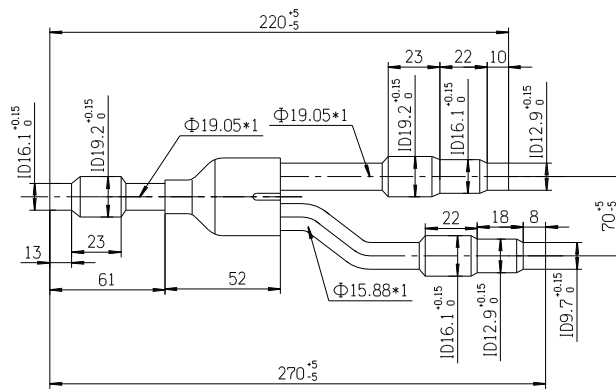

The sketch drawing for size of gas side Y shape three-way valve B as follows:

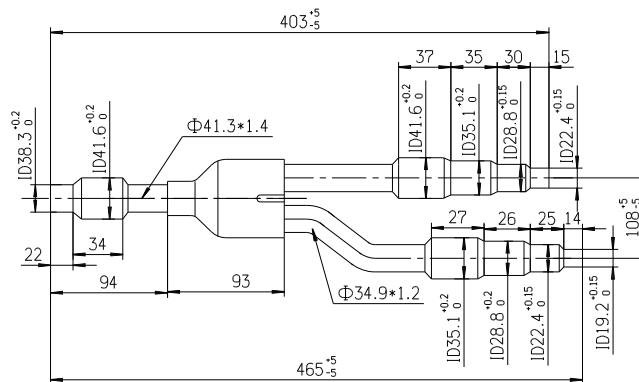

The model of gas side and liquid side Y shape three-way valve is RF-50B

• **Three modules combination**

(1) 46 HP - 48 HP

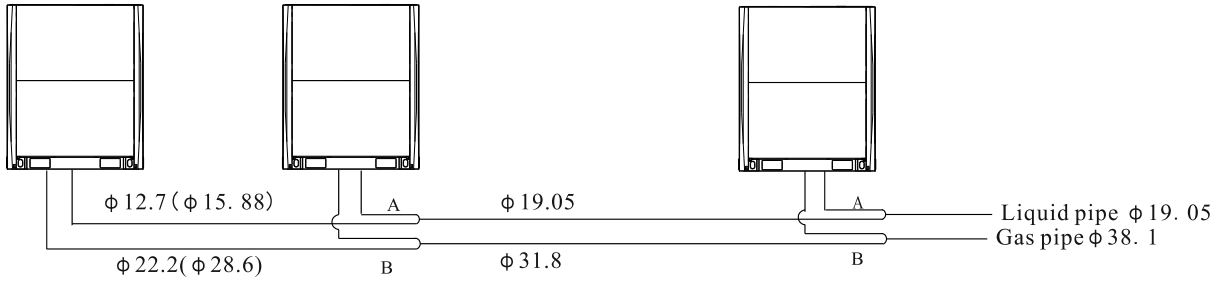

The model of gas side and liquid side Y shape three-way valve is RF-50B

(2) 50 HP - 66 HP

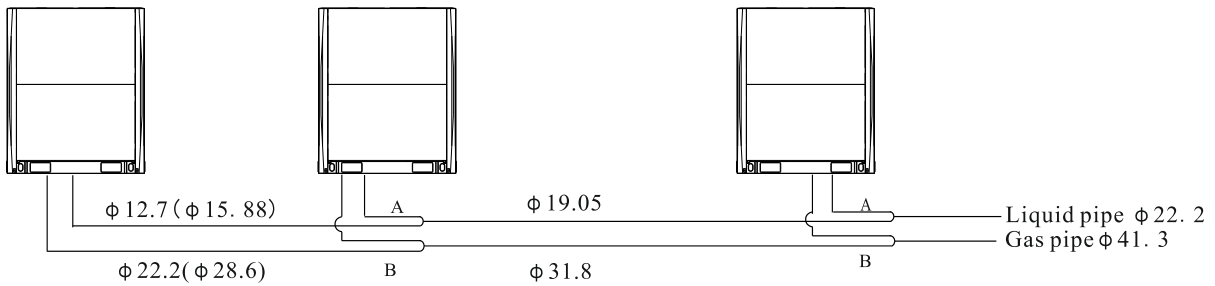

**Note:**

The sketch drawing for size of liquid side Y shape three-way valve A as follows:

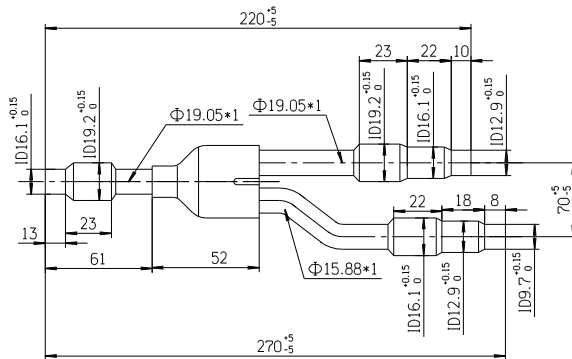

The sketch drawing for size of gas side Y shape three-way valve B as follows:

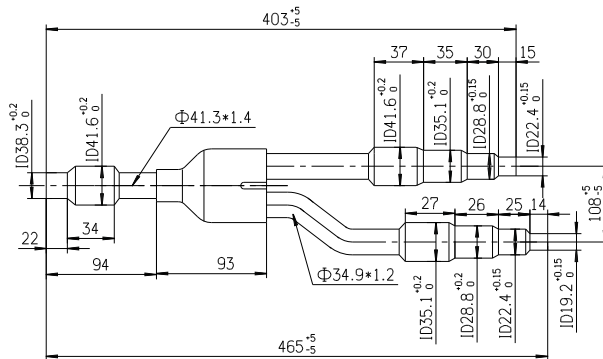

The model of gas side and liquid side Y shape three-way valve is RF-50B

# RICOS R-VRF 6 Outdoor Unit

- **Four modules combination**

68 HP - 88 HP

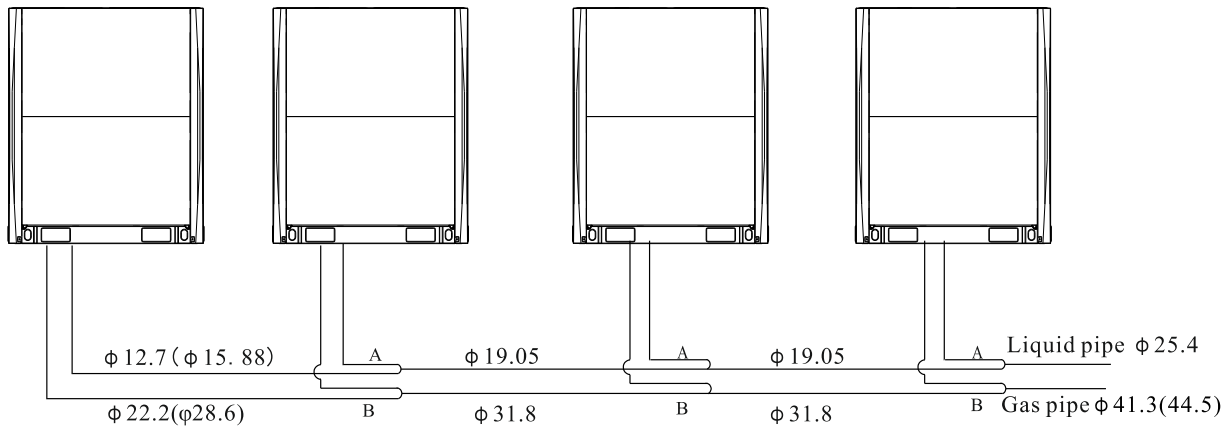

**Note:**

The sketch drawing for size of liquid side Y shape three-way valve A as follows:

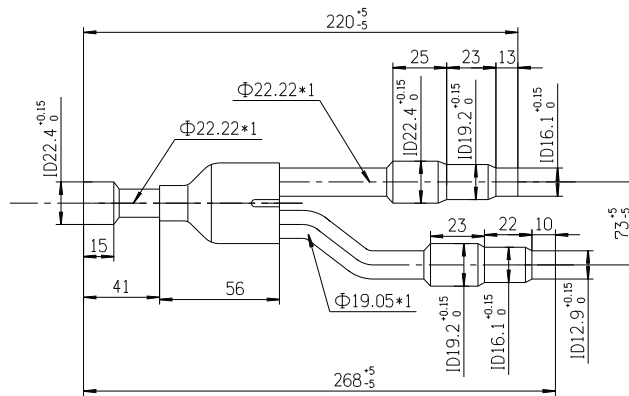

The sketch drawing for size of gas side Y shape three-way valve B as follows:

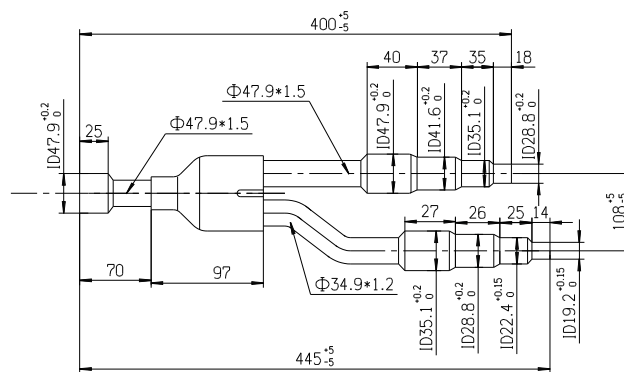

The model of gas side and liquid side Y shape three-way valve is RF-50B

**Table 3**

Diameter of piping 2 depends on the total capacity of indoor unit connected to the branch pipe.

Total capacity indoor unit (kW)	The main piping (gas side/liquid side)	Apply ramification
$A < 5.6$	$\Phi 12.7 / \Phi 6.35$	RF-00B
$5.6 < A < 16$	$\Phi 15.88 / \Phi 9.52$	RF-00B
$16 < A < 22.4$	$\Phi 19.05 / \Phi 9.52$	RF-00B
$22.4 < A < 33$	$\Phi 22.2 / \Phi 9.52$	RF-12B
$33 < A < 47$	$\Phi 28.6 / \Phi 12.7$	RF-24B
$47 < A < 68$	$\Phi 28.6 / \Phi 15.88$	RF-24B
$68 < A < 95$	$\Phi 31.8 / \Phi 19.05$	RF-34B
$95 < A < 140$	$\Phi 38.1 / \Phi 19.05$	RF-50B
$95 < A < 140$	$\Phi 41.3 / \Phi 22.2$	RF-64B
$180 < A$	$\Phi 44.5 / \Phi 25.4$	RF-64B

**Notice:**

1. The 1<sup>st</sup> branch pipe depends on the total capacity of outdoor unit, and the other branch pipe shouldn't not larger that the 1<sup>st</sup> branch pipe.
2. Transfer must be appropriate when the dimension between branch and main tube pipe isn't in conformity.

Eg: Take the (16+16+12) HP, three modules combinations as an example to illustrate the election of piping. (Assume that all piping equivalent length is less than 90 m).

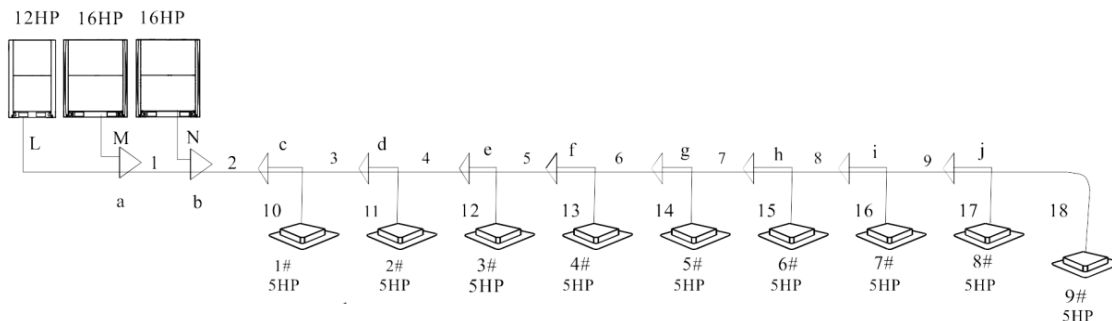

Parallel connections of outdoor modules.

(Diameter of main tube refers to table 2 according to the corresponding total capacity of outdoor unit.)

1. Pipe diameter of L, M, and N depends on HP of corresponding total capacity of outdoor unit, which is  $\Phi 22.2 / \Phi 12.7$ ,  $\Phi 28.6 / \Phi 15.88$ ,  $\Phi 28.6 / \Phi 15.88$  respectively.
2. Corresponding HP of 1 is "12 HP+16 HP=28 HP" and its pipe diameter is  $\Phi 31.8 / \Phi 19.05$ . Y-type branch pipe "a" should use the type of RF-34B.
3. Pipe "2" is main pipe. Dimension of both pipe "2" and Branch pipe depends on total capacity of outdoor unit. Sum of total capacity of outdoor units is "12+16+16=44 HP". Dimension of pipe "2" is  $\Phi 31.8 / \Phi 19.05$ . Y-type branch pipe "c" should use RF-50B and Y-type branch pipe "b" should use RF-50B.

For indoor side:

(Diameter of auxiliary pipe refers to table 4 according to model of indoor unit, and diameter of main pipe refers to table 3 according to the total capacity of indoor unit.)

## RICOS R-VRF 6 Outdoor Unit

---

1. Branch auxiliary pipes include 10-18 and the dimension of auxiliary pipe 10 is  $\Phi 15.88/\Phi 9.52$ , the dimension of auxiliary pipe 11-18 is  $\Phi 19.05/\Phi 9.52$ .
2. Downstream indoor units of main auxiliary pipe "9" include 8# and 9#. Its HP sum is "5+5=10 HP". Dimension of pipe "9" is  $\Phi 22.2/\Phi 9.52$ . Branch pipe "j" should use RF-12B.
3. Downstream indoor units of main auxiliary pipe "8" include 7#, 8# and 9#. Its HP sum is "5\*3=15 HP". Dimension of pipe "8" is  $\Phi 28.6/\Phi 12.7$ . Branch pipe "i" should use RF-24B.
4. Downstream indoor units of main auxiliary pipe "7" include 6#- 9#. Its HP sum is "5\*4=20 HP". Dimension of pipe "7" is  $\Phi 28.6/\Phi 15.88$ . Branch pipe "h" should use RF-24B.
5. Downstream indoor units of main auxiliary pipe "6" include 5#- 9#. Its HP sum is "5\*5=25 HP". Dimension of pipe "6" is  $\Phi 28.6/\Phi 15.88$ . Branch pipe "g" should use RF-24B.
6. Downstream indoor units of main auxiliary pipe "5" include 4#- 9#. Its HP sum is "5\*6=30 HP". Dimension of pipe "5" is  $\Phi 31.8/\Phi 19.05$ . Branch pipe "f" should use RF-34B.
7. Downstream indoor units of main auxiliary pipe "4" include 3#- 9#. Its HP sum is "5\*7=35 HP". Dimension of pipe "4" is  $\Phi 31.8/\Phi 19.05$ . Branch pipe "e" should use RF-34B.
8. Downstream indoor units of main auxiliary pipe "3" include 2#- 9#. Its HP sum is "5\*8=40 HP". Dimension of pipe "3" is  $\Phi 38.1/\Phi 19.05$ . Branch pipe "d" should use RF-50B.



### Remote The Garbage And Water From The Piping

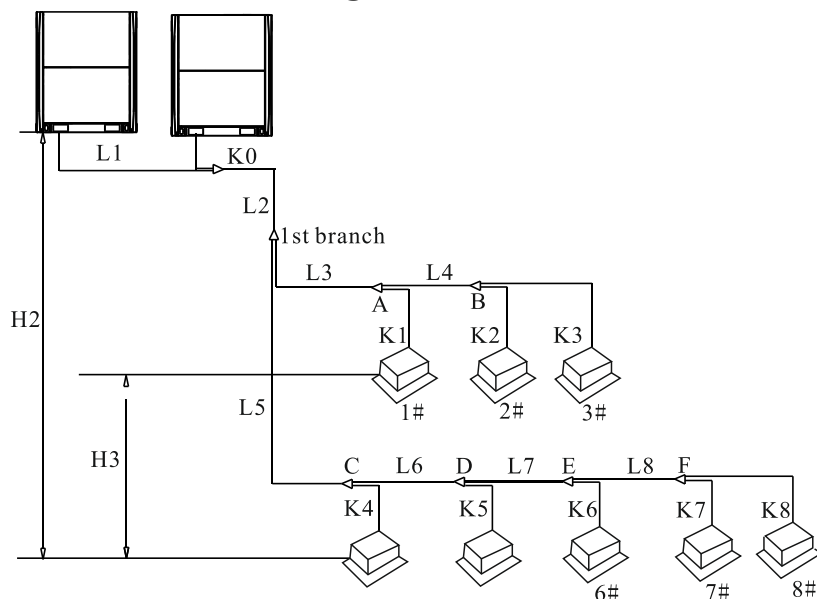

		Allowable value	Part of Auxiliary pipe	
<b>Piping Length</b>	Max. Total piping length	1000 m	Example: $L1+L2+L3+L4+L5+L6+L7+L8+k0+k1+k2+k3+k4+k5+k6+k7+k8 \leq 1000$ m	
	Max. Equivalent length between outdoor unit and farthest indoor unit	240 m	Example: Unit 8: $L1+L2+L5+L6+L7+L8+k8 \leq 240$ m	
	Max. piping length from 1 <sup>st</sup> indoor unit branch to the farthest indoor unit	40 m	Example: Unit 8: $L5+L6+L7+L8+k8 \leq 40$ m	
		90 m*	Example: Unit 8: $L5+L6+L7+L8+k8 \leq 90$ m &Unit 8-unit: $(L5+L6+L7+L8+k8)-(L3+K1) \leq 40$ m	
	Level difference Between ODU&IDU	ODU is up	110 m	Example: $H2 \leq 110$ m
		ODU is down	110 m	Example: $H2 \leq 110$ m
Level difference among indoor units		30 m	Example: $H3 \leq 300$ m	

**Note:**

**It is necessary to increase the pipes size of the liquid and gas piping if the equivalent length between indoor unit and the first branch pipe is over 40 bm.**

### Leakage Testing

1. After finishing the piping connection of outdoor unit, please connect the high pressure side piping and high pressure valve.
2. Make the low pressure side piping and mater joints accessory well-welded.
3. Charge the nitrogen gas from connection point of high side valve and mater joints, then start the leakage testing.
4. After the leakage testing, please make the low pressure ball valve and low pressure valve well-welded.

**Note :**

1. The nitrogen gas [4.2 MPa (43 kgf/cm<sup>2</sup>)] with a certain pressure is used for the leakage testing.
2. It is not allowed to charge the nitrogen gas after the connection of low pressure side piping and low pressure valve.
3. It is forbidden to use oxygen, flammable gas and poisonous gas.
4. Use wet cloth to wrap the high pressure valve and balance valve.

**Use Vacuum Pumps For Vacuuming**

- Use vacuum pump for vacuuming, refrigerant gas is not allowed for air exclusion.
- Vacuuming is started from the liquid side and the gas side at the same time, it is also necessary for gas balance piping and oil balance piping to vacuum, what is more it is vacuum request is less than 30 Pa.

**With All The Valves ON**

**Extra Refrigerant Value**

According to the diameter and length of the liquid side connection pipe for outdoor unit and indoor unit to calculate the extra refrigerant value, the refrigerant is R410a.

Diameter for Liquid side piping	Extra refrigerant value to the effective 1 m pipe length
Φ25.4	0.45 kg
Φ22.2	0.34 kg
Φ19.05	0.25 kg
Φ15.88	0.17 kg
Φ12.7	0.11 kg
Φ9.52	0.054 kg
Φ6.35	0.022 kg

**Address Dial Code For Outdoor Unit**

- Address dial code for outdoor unit norm as following:

Address for outdoor unit	
0#	00
1#	01
2#	10
3#	11

Notice: In the table, 0 means switch “Number”, 1 means switch “ON”. When you want to change any set, please consult our factory first.

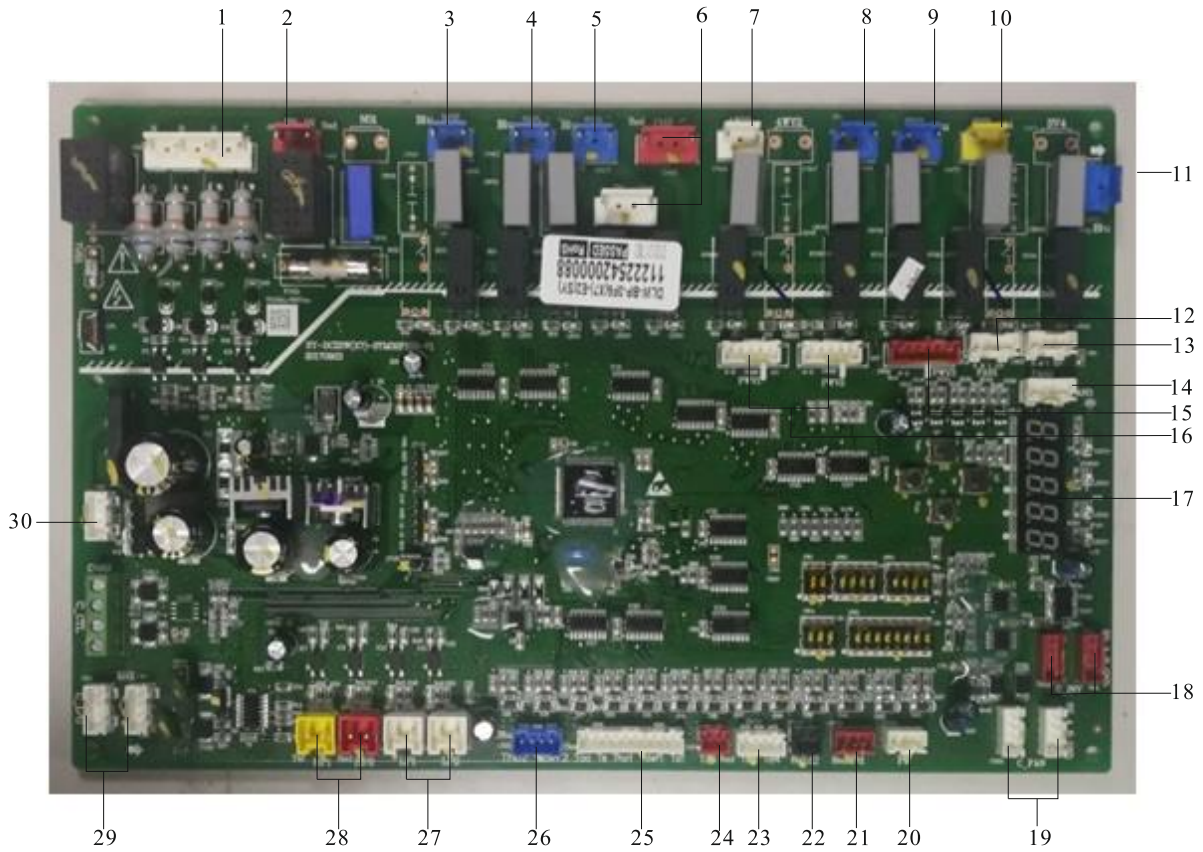

1	NRST	16	PMV1, PMV2
2	Tran in	17	digital tube
3	Contactor	18	INV COMP signal
4	Sv5	19	DC fan signal
5	Sv6	20	Ps
6	CH1, CH2	21	Ph
7	SVO	22	Td2
8	SV1	23	Toil, Tliq
9	SV2	24	Td1
10	SV3	25	SW2C
11	SV7	26	Tgi, Tgo
12	FAN1 (obligate)	27	LP1, LP2
13	FAN2 (obligate)	28	HP1, HP2
14	FAN3 (obligate)	29	In/out BUS, A1 B1 A2 B2
15	PMV3	30	Tran out

### Electrical Connections

<b>WARNING</b>
All electrical works must be carried out & checked by a qualified electrician and must adhere to the IET regulations, local and national legislation and industry best practice. The system must have its own independent power supply. An all pole isolating disconnect switch with at least 3 mm contact separation must be installed. The power cord and connecting cable should be either as supplied with the unit or otherwise as specified in this manual. Do not attempt any electrical works yourself.
An Earth Leakage Protector, Power Switch and Circuit Breaker or Fuse must be installed in the dedicated power supply or there is the risk of electric shock.
The fuse specification of indoor unit single-phase control panel is T3, 15AL 250 V; The fuse specification of outdoor unit single-phase control panel is T6, 3AL 250 V; The fuse specification of three-phase control panel is T3, 15AL 250 V; The fuse specification of fan motor is T10AL 250 V.
The grounding must be reliable. If grounding is not correct, it may lead to electric shock.
All power cables should be properly secured with cable ties so that external forces cannot disconnect the wires from the terminals. Improper connections or insecure fastening can cause electric shocks or fire.
If the supply cord is damaged, it must be replaced by the manufacturer, its service agent or similarly qualified person in order to avoid a hazard.

<b>CAUTION</b>
Do not connect the earth cable to gas or water pipes, telephone lines, lightning rods or the earth cables of other products.
Do not connect the earth cable to gas or water pipes, telephone lines, lightning rods or the earth cables of other products.

- Please connect the power cord and interconnecting cable according to the wiring diagram.
- Connect the wire firmly to the terminal block using crimps and secure in order to prevent external forces pulling on the wire causing risk of fire or electric shock.
- After the electrical connection is completed, all wires should be prevented from touching other parts such as tubing, compressor etc.
- Please design specialized power for both outdoor and indoor units respectively.
- Design the connection wiring system for outdoor unit and wiring system for refrigerant as the same system.
- Indoor signal wire and wire controller matching wire are low voltage return circuit, as a result, high voltage matching wire direct connection shouldn't be in same wire tube.

## Power Wiring

(Outdoor unit wiring for signal wire)

Type	Power cut area (mm <sup>2</sup> )	Ground wire cut area (mm <sup>2</sup> )	Circuit Breaker (A)
8 HP	4	4	32
10 HP	6	6	32
12 HP	6	6	40
14 HP	6	6	50
16 HP	6	6	50
18 HP	10	10	63
20 HP	10	10	63
22 HP	16	16	63

T3 models

Type	Power cut area (mm <sup>2</sup> )	Ground wire cut area (mm <sup>2</sup> )	Circuit Breaker (A)
8 HP	6	6	32
10 HP	6	6	32
12 HP	6	6	32
14 HP	6	6	50
16 HP	10	10	63

Sketch drawing for outdoor wiring

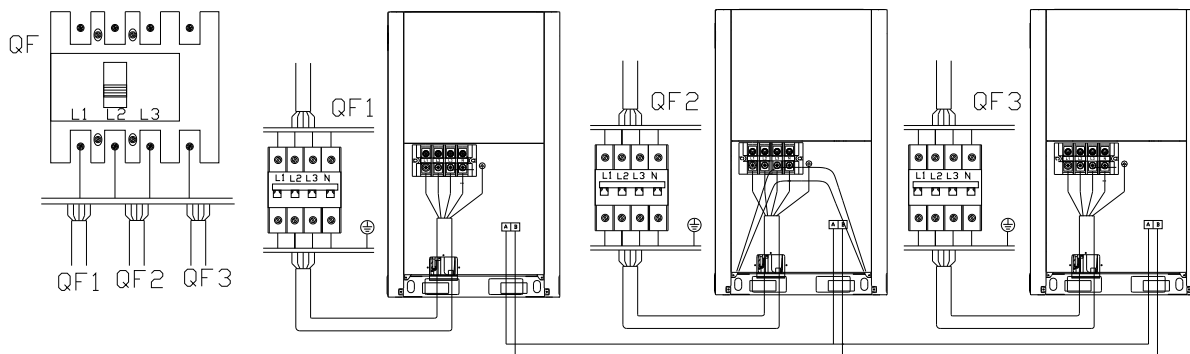

Drawing for signal wiring of indoor and outdoor unit

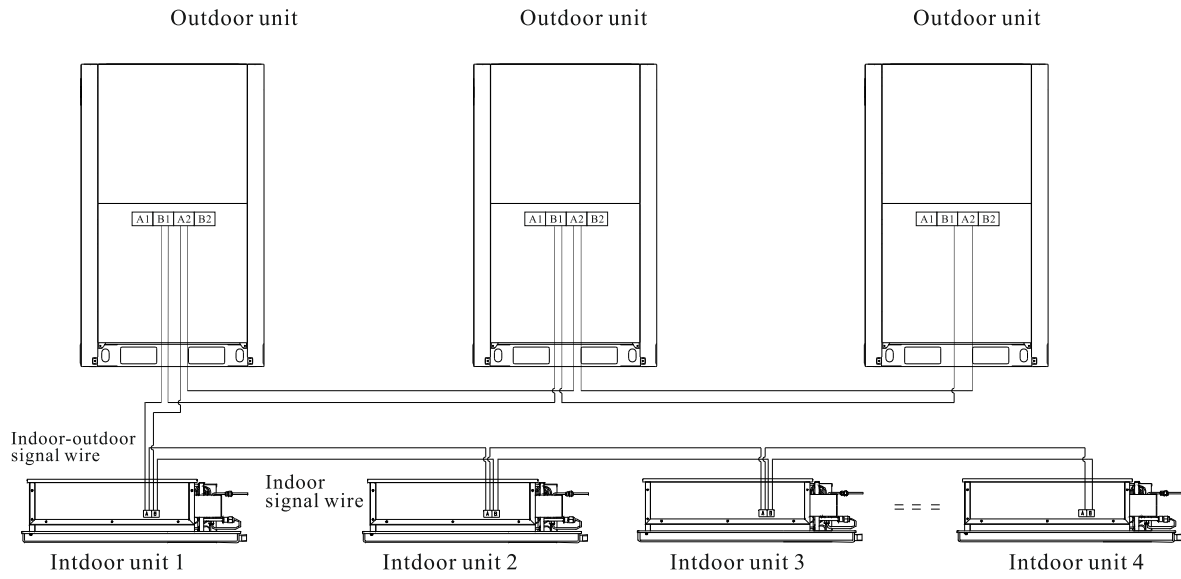

### Trial Operation

Please finish it according to the indication “attention for operation” on the electrical appliance cover.

**Note:**

1. Trial operation of outdoor unit must be started after powered on more than 12 hours.
2. Make sure all valves are open, then start the trial operation.
3. Compulsive operation is definitely prohibited.

### Fill Out The Names For Connection System

In order to identify the indoor unit system from the outdoor unit when setting several indoor units, you should nominate every system and notify them on refrigerant of electrical control box for outdoor unit.

Indoor unit type	
Room name Example:second floor, first system, indoor Mark:-2F-1	

## Refrigerant Leakage For Operation

R410a is applied as the refrigerant. R410a is not toxic in itself, and this material is noncombustible. Proper room in size for the central AC is required, so, the concentration of refrigerant will not exceed the limit in case of leaking. Beside this, other necessary measures can be taken.

- Limit concentration-the non-harmful concentration of Freon gas Limit concentration of R410a: 0.3 [kg/m<sup>3</sup>].

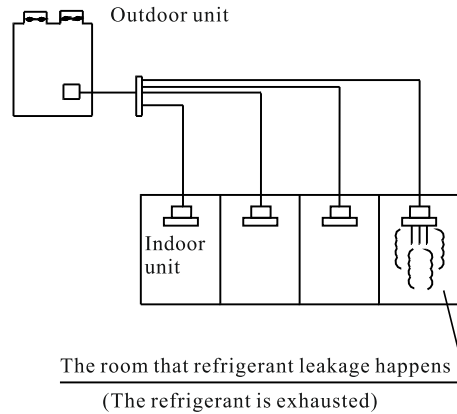

Confirm the limit concentration as following and take relevant essential measures.

1. Calculate out the entire filling value of refrigerant (A [kg])  
Entire value = Filling value when for sale (13 [kg])+extra value for relevant matching pipe.
2. Calculate out the indoor room volume (according to minimum volume)  
Calculate out the volume of refrigerant.

$$\frac{A[\text{kg}]}{B[\text{m}^3]} \leq \text{the limit concentration : } 0.3 [\text{kg}/\text{m}^3]$$

Countermeasure for excessive concentration

1. In order to reduce the concentration under the limit, you are strongly recommended to install mechanical hood. (ventilation should be usual)
2. Please install leakage alarming device connected to mechanical ventilation equipment when frequent ventilation is impossible.

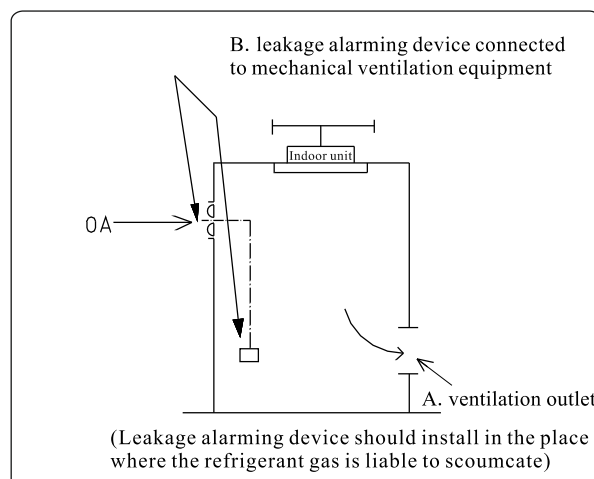

## Electric Wiring

### Note:

- Please design specialized power for both outdoor and indoor units respectively.
- Power should be designed as specialized an branched return circuit, install power leakage protector, manual switch.
- Power leakage protector and manual switch must be universal as to the power of indoor units connected to same outdoor unit. (same return circuit for outdoor unit power in same system: on/off conditions should be synchronous)
- Design the connection wiring system for outdoor unit and wiring system for refrigerant as the same system.
- In order to reduce the disturb, double-core shield double twist wires as the signal wire for indoor unit. Don't apply the double-core wire.
- Please conduct the relevant national standard for electricians.
- Power wiring must be finished by electrician.

### Note:

Indoor signal wire and wire controller matching wire are low voltage return circuit, as a result, high voltage matching wire direct connection shouldn't be put in same wire tube.

Sketch drawing for outdoor wiring

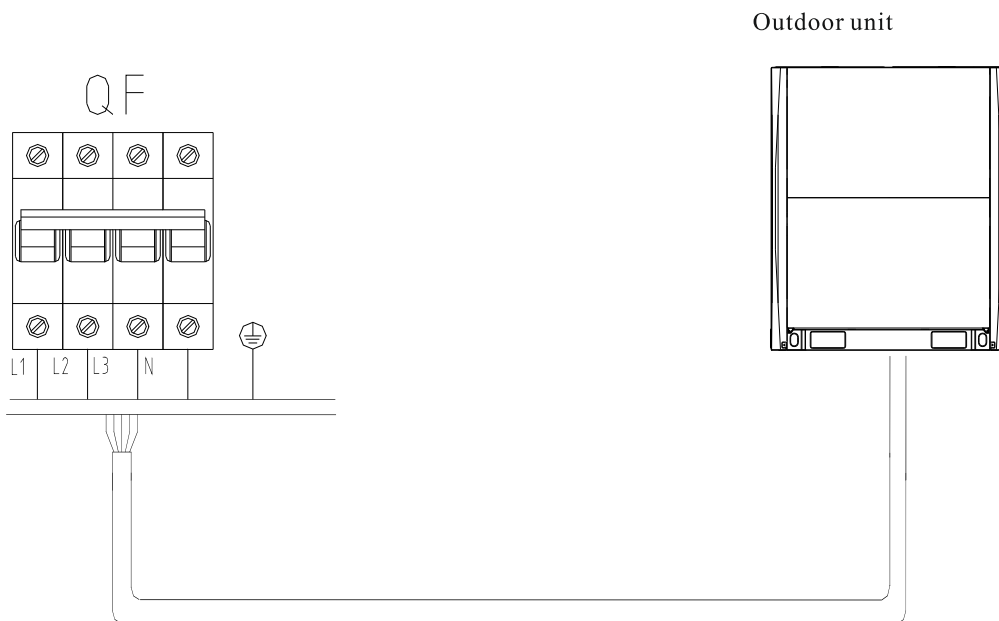



Drawing for signal wiring of indoor and outdoor unit

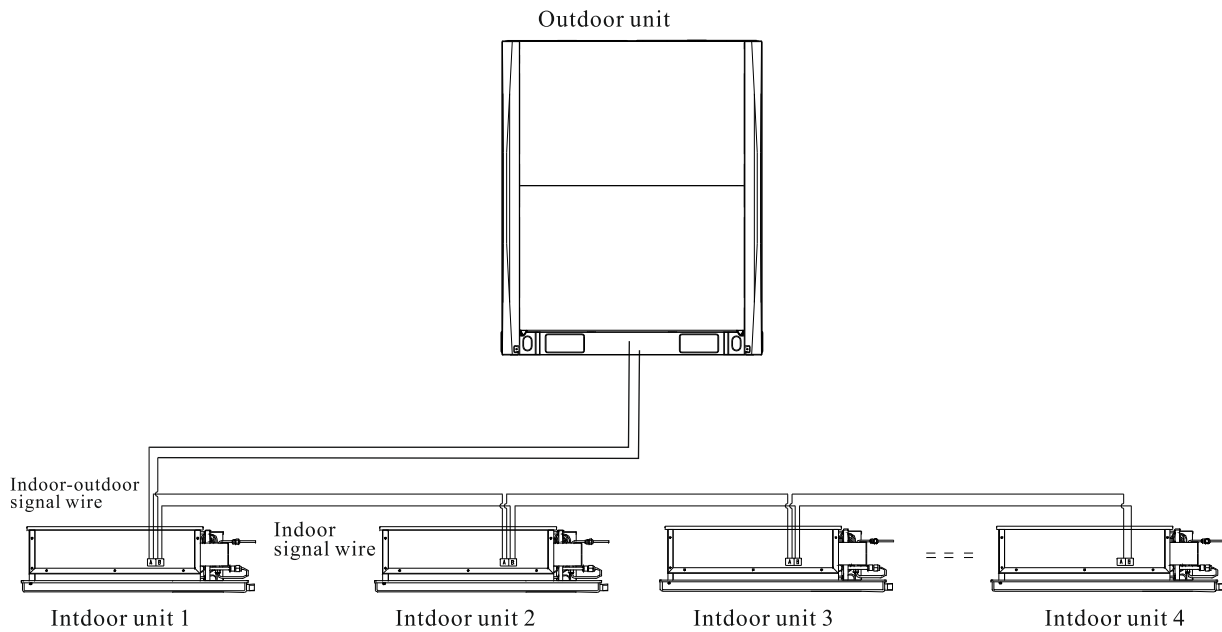

**Trial Operation**

Please finish it according to the indication “attention for operation” on the electrical appliance cover.

**Note:**

1. Trial operation of outdoor unit must be started after powered on more than 12 hours.
2. Make sure all valves are open, then start the trial operation.
3. Compulsive operation is definitely prohibited.

**Fill Out the Names for Connection System**

In order to identify the indoor unit system from the outdoor unit when setting several indoor units, you should nominate every system and notify them on refrigerant of electrical control box for outdoor unit.

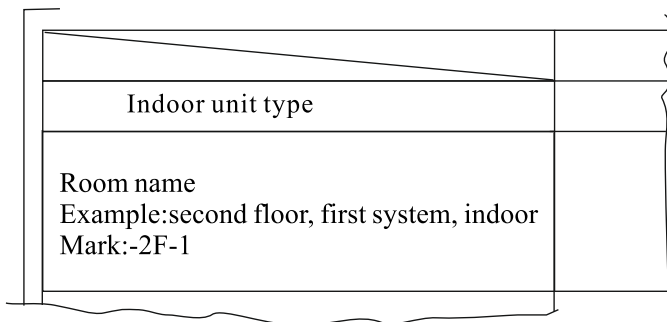

## Refrigerant Leakage For Operation

R410a is applied as the refrigerant. R410a is not toxic in itself, and this material is noncombustible. Proper room in size for the central AC is required, so, the concentration of refrigerant will not exceed the limit in case of leaking. Beside this, other necessary measures can be taken.

- Limit concentration-the non-harmful concentration of Freon gas Limit concentration of R410a: 0.3 [kg/m<sup>3</sup>].

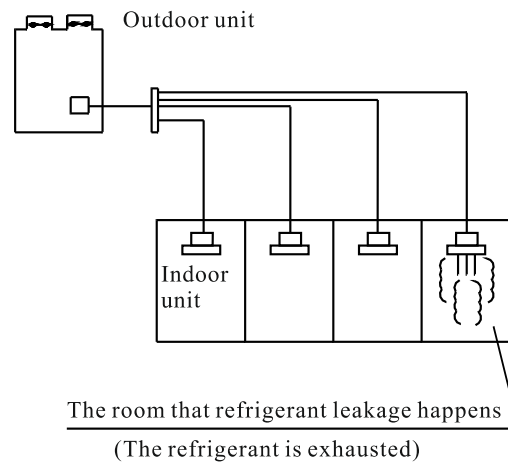

Confirm the limit concentration as following and take relevant essential measures.

1. Calculate out the entire filling value of refrigerant (A [kg])  
Entire value = Filling value when for sale (13 [kg])+extra value for relevant matching pipe.
2. Calculate out the indoor room volume (according to minimum volume)  
Calculate out the volume of refrigerant.

$$\frac{A[\text{kg}]}{B[\text{m}^3]} \leq \text{the limit concentration : } 0.3 [\text{kg}/\text{m}^3]$$

Countermeasure for excessive concentration

1. In order to reduce the concentration under the limit, you are strongly recommended to install mechanical hood. (ventilation should be usual)
2. Please install leakage alarming device connected to mechanical ventilation equipment when frequent ventilation is impossible.

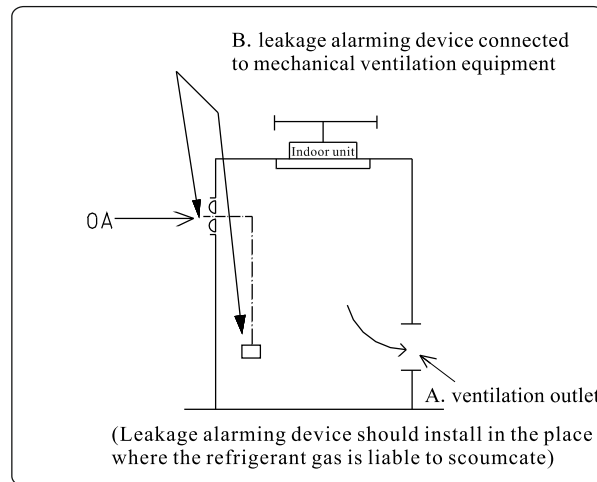

## Project Commissioning & Debugging

1. Key-display system:



2. Basic Steps of Project Commissioning  
Power on. Then the main PCB digital tube displays “d. “. it means the system is waiting for commissioning: if it displays standby “1.\_.\_. 16” or locking “LoC.”, it means that the system has finished commissioning.
3. Basic Operations of Project Commissioning asic Operat
  - Enter/exit  
Long press “Fun” button for more than 5 secs to enter project commissioning; then, long press “Test” button for more than 5 secs to exit.
  - Quick finish  
After completing Step “3”, long press “Fun”+“Test” buttons for more than 5 secs to complete project commissioning in advance, the system enters the state of normal standby.
- 3.1. Master unit setting and Indoor unit addressing mode selection  
The system must set DIP address to make one module as master unit, the rest are slave unit. After setting master and slave-units correctly, digital tube displays “1.\_.\_. 0” (the left means 1<sup>st</sup> step, the right shows the addressing mode, “0” means manual addressing, “1” means automatic addressing), press “Up” or “Down” button to choose, short press “Fun” to confirm; after confirmation, digital tube displays “1. 0” or “1. 1”, 2 secs later, enter step 2. Attention, if manual addressing is chosen, manually set the indoor unit address by remote controller or linecontroller.  
If you choose manual addressing 1 \_.\_. 0, you need to manually set IDU address.

- 3.2. Determination of the quantity of outdoor unit modules  
Digital tube displays "2.\_.\_ 1" (the left means 2<sup>nd</sup> step, the right shows the quantity of outdoor units), if display quantity and actual quantity are inconsistent, need to conduct manual check (DIP address, communication line and etc.) and commissioning confirmation. If they are consistent, short press "Fun" button to confirm, digital tube displays like "2. 1" or, 2 secs later, enter step 3.
- 3.3. Determination of the quantity of indoor units  
Digital tube displays "3.\_.\_ 16" (the left means 3<sup>rd</sup> step, the right shows the quantity of outdoor units), if display quantity and actual quantity are inconsistent, need to conduct manual check (power lines and communication lines of indoor units, and etc.) and commissioning confirmation. If they are consistent, short press "Fun" button to confirm, digital tube displays like "3. 16", 2 secs later, enter step 4.
- 3.4. Confirmation of the internal communication of outdoor units  
Automatically detects the communication between master controller and driver; after 2 secs, if the communication with the fan driver is faulty, it displays "4. 13", all buttons are invalid, cannot enter the next judgment, if it is normal, then the module displays "4.\_.\_ ". If the internal communication of outdoor electronic control box is normal, then conduct system indoor and outdoor units ratio test, if it is out of range, display "4. \_1\_1", if ratio is normal, 2 secs later, enter the next step.
- 3.5. Confirmation of the internal components of an outdoor unit  
Automatically check components of outdoor units, being detected, display "5.\_.\_ ". If it's failure, then corresponding failure displays, for example, "5. 1.F 4 "; the left means step 5, the middle is the faulty outdoor unit's address, the last two is fault code. Only displays the fault with the highest priority. If all failure are solved, display normally; in case that several modules occur faults, displays the fault codes in turn by address order. It cannot enter the next judgment; if all faults are solved, digital tube displays "5. " 2 secs later, enter step 6.
- 3.6. Adjustment on the components of an indoor unit  
Digital tube displays "6.\_.\_ ", if one indoor unit occurs a fault, display project number circularly, and the fault code like "6. 5.A 4 ". If several indoor unit occur faults, display the addresses and the fault code circularly. At that moment, all buttons are invalid, cannot enter the next step. If no fault, digital tube displays "6. ", 2 secs later, enter step 7.
- 3.7. Confirmation and adjustment of compressor preheating  
If the outdoor unit has been continuously energized for more than 6 hours, displays "7. ", means the completion of preheating, 2 secs later, enter step 8. Otherwise display "7.4 = 36 ". The first digit means step 7, the rest indicates preheating time (hour : min). Short press "Fun" button, can skip waiting and enter step 8.
- 3.8. Refrigerant judgment before starting  
Refrigerant judgment, display "8.\_.\_ ". If any [module low pressure P secs] ≤ -25 °C, then report refrigerant lack protection, display "8. H 5 ", all buttons are invalid, it required to check if the system refrigerant is normal, or there is any leakage. If it is normal, display "8. ", 2 secs later, enter step 9.
- 3.9. Status judgment on outdoor unit valve before starting  
The status judgment of outdoor unit valve "9.\_.\_ ", 2 secs later, enter the next step.
- 3.10. Confirmation of start commissioning  
This step, displays "10.\_. ", waiting for start commissioning. Press "Fun" button to start, automatically select operating mode according to outdoor environment

temperature:  $\geq 20\text{ }^{\circ}\text{C}$ , running cooling model;  $< 20\text{ }^{\circ}\text{C}$ , running heating model, 2 secs later, automatically enter the next step (step 11 or step 12), digital tube displays “10. ”.

3.11. Commissioning of cooling operation

Refrigerant operation, all indoor units are turned on, setted  $16\text{ }^{\circ}\text{C}$ &high speed, digital tube displays “11. ”. In the operation, if it’s failure, displays “Err” and fault code, like “Err.F3”. 20 min later, or accumulated for 25 min, if the system is not abnormal, displays “1. 16” or locking “LoC ”. Project commissioning is finished.

3.12. Commissioning of heating operation

Heating operation, all indoor units are turned on, settled  $30\text{ }^{\circ}\text{C}$ &high speed, digital tube displays “12. ”, after 10 min, if it is normal, display will not change, 20 min later, or accumulated for 25 min, if the system is not abnormal, displays “12. ”, after 5 s, enter normal standby status “1. 1.6” or locking “LoC ”. Project commissioning is finished.

**Function and Parameter**

3. Instructions of Function

Function list and option guidance shows in the table below, items can be set in 2 ways as follow

- (1) by dial switch (turn off - on the power after you change the switch).
- (2) by key and menu option.

Function names	Option method	Switch/Function number
Silent	Switch	SW5-1, 2
Model priority	Switch	SW5-3, 4
Static pressure	Switch	SW5-5, 6
Comp emergency	Switch	SW4-1, 2
ODU emergency	Switch	SW4-3
IDU/ODU rate	Key and menu	1
Clean	Key and menu	2
Variable ET	Key and menu	3
Blow off snow	Key and menu	4
Vacuumize	Key and menu	5
$26\text{ }^{\circ}\text{C}$	Key and menu	6
Refrigerant recycle	Key and menu	7
Auto-fill	Key and menu	8

1.1. Functions set by switch

Comp emergency	ODU emergency	Silent	Model priority	Static pressure
SW4-1, 2:	SW4-3:	SW5-1, 2:	SW5-3, 4 :	SW5-5, 6 :
00 : comp1 normal	0 : this ODU normal	00 : without silent	00 : first dominant	00: without
01 : comp1 emergency	1 : this ODU emergency	01 : silent night	01 : heating dominant	01 : low

10 : comp2 emergency		10 : normal silent	10 : cooling dominant	10 : mid
11 : comp2 emergency		11 : super model	11 : few obey more	11 : high

**Notice:**

**In the table, 0 means switch “Number”, 1 means switch “ON”. When you want to change any set, please consult our factory first. When you set Comp or ODU emergency, please close the Gas/Liquid valve, and solve the problem in 24-48 h, because the emergency can only work long. After solveing the problem, please cancel emergency setting, or the ODU can not run.**

1.2. Functions set by key and menu

Function names	Remember or not	Display	Instructions
IDU/ODU rate	Y	/	Set max IDU/ODU rate allowed
Clean	N	CLE.	Outdoor fan run in special model to clean the condenser
Variable ET	Y	/	3 different evaporate temperature : normal, energy saving, comfort
Blow off snow	Y	/	Set cycle for blowing off snow on the top
Vacuumize	N	PuA.	Ready for vacuumize
26 °Clock	Y	/	Setting temperature lock at 20/26 °C
Ref recycle	N	rCCL	Recycle refrigerant to ODU

**2. Function/Parameter Checking and Setting**

2.1. Key-display And Switch Guidance

There is a key and menu system for function Checking/Setting or display. The 1<sup>st</sup> step is main menu, 2<sup>nd</sup> step is for function choosing, 3<sup>rd</sup> step is for checking/setting parameter of some functions. Press Fun key to the below step, Press Test key to the up step, Press Up, Down key to choose the function or parameter you want. After Debugging and lock-relieving, the system is standing-by, press Fun key for 2 second into the 1<sup>st</sup> step --- the Main menu, digital tube displays like “E. ” (shane).

The 1<sup>st</sup> step --- the Main menu include Status Checking E. , Parameter Checking P. , Parameter Setting C. , Debug d. , Restor to factory setting . , press Up or Down key to choose the “function you want, then press Fun-key into the function to check or set.

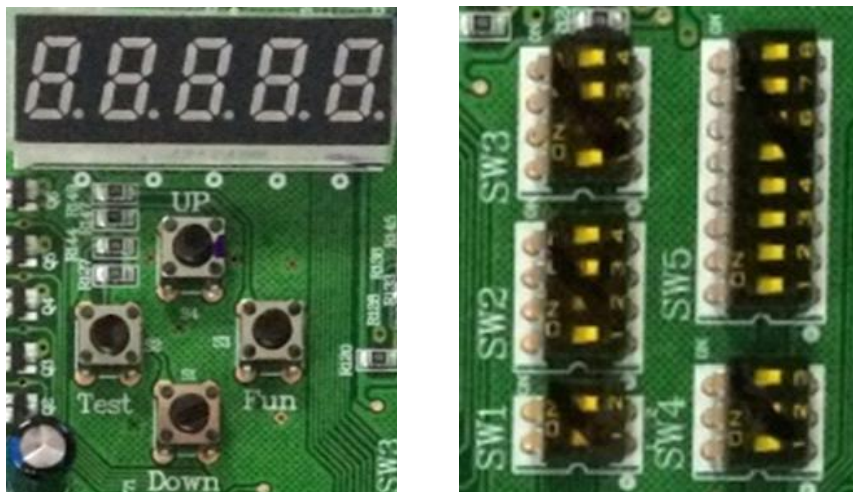

2.2. Status Checking

In the 1<sup>st</sup> step --- Main menu, choose Status Checking E. , press Fun key into the 2<sup>nd</sup> step, then you can check the running status of the system, like frequency of compressor and so on.

For example:

Digital displays like 1. 6 4.0, means parameter name corresponding No. 1, 640 means the parameter is 64, whole means frequency of comp 1 is 64 rps. The number and parameter name corresponds as below:

No	Parameter name	units	No	Parameter name	units
1	Freq of comp 1	rps	11	Tei 1 (inlet of condenser 1)	0.1 °C
2	Freq of comp 2	rps	12	Tei 1 (inlet of condenser 2)	0.1 °C
3	Step of PMV1	Pls	13	Tdef 1 (defrost temperature)	0.1 °C
4	Step of PMV2	Pls	14	Tdef 2 (defrost temperature)	0.1 °C
5	Pd_t	0.1 °C	15	Gas inlet of plate heat exchanger temperature	0.1 °C
6	Ps_t	0.1 °C	16	Gas outlet of plate heat exchanger temperature	0.1 °C
7	Temp of comp 1	0.1 °C	17	Liquid outlet of plate heat exchanger temperature	0.1 °C
8	Temp of comp 2	0.1 °C	18	Oil temperature	0.1 °C
9	Tao	0.1 °C	19	Edition of procedure	/
10	Ts (suction)	0.1 °C			

## 2.3. Parameter Checking

In the 1<sup>st</sup> step --- Main menu, choose Parameter Checking P. , and press Fun key, then you can check parameter of some functions by choosing the number in the table below.

For example: Digital displays like P. 1 (P-light, 1-shane), then press Fun key to the down step, it will show you a parameter like 135, means the max rate of IDU/ODU (No 1) is setted 135 %.

Function number	Function name	Remember or not
1	Rate of IDU/ODU	Y
3	Variable Evaporate Temperature	Y
4	Blow off snow	Y
6	26 C Lock	Y

## 2.4. Function/Parameter Setting

In the 1<sup>st</sup> step --- Main menu, choose Parameter Setting [. , press Fun key, then you can set some Function/Parameter you want by choosing the Function Number.

For example: Digital displays [. 1 (C-light, 1-shane), press Up or Down key to choose the number of function you want, then press Fun key to get into down step to set if it's need. Change the setting by pressing Up or Down key, then Fun key to confirm. The function name and number show in the table below.

Function names	Option			Notice
	1 <sup>st</sup> step Main menu	2 <sup>nd</sup> step Function Number Choosing	3 <sup>rd</sup> step Parameter Setting	
Rate of IDU/ODU	[.	1	135 : IDU/ODU≤135 % 200 : IDU/ODU≤200 %	135 is default, when you change it, it will influence the comfort, please consult our factory first.
Clean		2	/	Choose the number at 2 <sup>nd</sup> step and confirm, the outdoor fan will run immediately, only one time.
Variable ET		3	Choose number to set model 0 : normal 1 : energy saving 2 : comfort	0 is default, when you change it, it will influence the comfort or power consumption
Blow off snow		4	Choose number to set cycle 0 : without this function 1 : 0.5 h 2 : 1 h 3 : 3 h 4 : 10 h	After pressing Fun key to confirm, the outdoor fan will run to blowing off snow automatically and cycle by cycle, if you choose 1, 2, 3, 4
Vacuumize		5	/	Choose the number at 2 <sup>nd</sup> step and confirm, the ODU will be ready for vacuumize. If set on the Master unit, the system.



26 °C		6	Choose number to set model 0 : without this function 1 : lock 20/26 °C	If choose 1, the IDU setting temperature will be locked at 20 °C in heating model and 26 °C in cooling model at any time.
Ref recycle		7	/	Recycle refrigerant to ODU
Auto-fill		8	/	Choose number 8 at 2 <sup>nd</sup> step and confirm to start Auto-fill. Please red refrigerant filling module carefully, and operate as it requires.

### Refrigerant charging

Calculate the additional amount according to the condition of pipe connection before debug. If the refrigerant is insufficient after debugging, additional refrigerant is required, which can be operated automatically or manually.

#### Automatic filling method

Refrigerant filling	Into the Function	After the commissioning of the project, through the function menu, choose C. 8 to enter the Auto-fill function. Then, all the ODU and IDU will run up automatically.
	Refrigerant judge	Judgement: It will display F I L L. until it is stable. (The Judgement keeps about 15 minutes).
	Refrigerant state	After Refrigerant judge, it will show you the situation of the system on the digital tube as follow: <ul style="list-style-type: none"> <li>• F. 1 lack refrigerant. Need to add refrigerants by automatic infusion or manual infusion.</li> <li>• F. 2 It's ok. No need to add or reduce.</li> <li>• F. 3 Too much refrigerant. Need to reduce some refrigerant.</li> </ul>
	Refrigerant filling process	The process of adding and reducing: <ul style="list-style-type: none"> <li>• When the digital tube display F. 1, press Fun key to start refrigerant filling, when displays F. 2, means that it is about to complete. 3 minutes later, it turns to F. 0, means that the filling is finished and the system will stop running automatically. Then please close the service valve. About 3 minutes later the system will stop running.</li> <li>• When it displays F. 3, you need to reduce some refrigerant. Then it displays F. 2, means the reducing will finish in a few mins. When it turns to F. 0, means it's completed, about 3 minutes later the system will stop running automatically. Please finish reducing and close the service valve.</li> </ul>
	Function exit operation	Exit the operation, fill the end: <ul style="list-style-type: none"> <li>• Long press Test key 5 seconds, force withdrawal refrigerant filling, the machine enters standby state.</li> <li>• When the digital tube display F. 0, press the function key to confirm the filling completed, the machine entered standby state.</li> <li>• When refrigerant filling continues 30* N minutes (N for the numbers of modules), force with drawal refrigerant filling, the machine enters standby state.</li> </ul>

**Notice:**

1. When adding refrigerant, please wear safety goggles and safety gloves.
2. Before adding refrigerant, please check the situation of pipe connection, wire connection, vacuuming, installation.
3. Adding refrigerant from the service valve!
4. When adding refrigerant, you should turn down the tank to make sure it's adding liquid refrigerant.
5. After adding refrigerant, please close the service valve, or it will add too much, because the refrigerant will keep adding by pressure-drop even though the system has stopped running.
6. Auto Refri-add can only be used in such conditions:  $15\text{ }^{\circ}\text{C} \leq T_{\text{outdoor}} \leq 40\text{ }^{\circ}\text{C}$  and  $10\text{ }^{\circ}\text{C} \leq T_{\text{indoor}} \leq 32\text{ }^{\circ}\text{C}$ , and IDUs (capacity  $\leq 1.5\text{ HP}$ ) is less than 70% in the system.
7. When the outdoor temperature is about  $35\text{ }^{\circ}\text{C}$ , it can add about 25 kg per hour (At  $15\text{ }^{\circ}\text{C}$ , it becomes 15 kg per hour.)

**Flow chart of refrigerant filli**

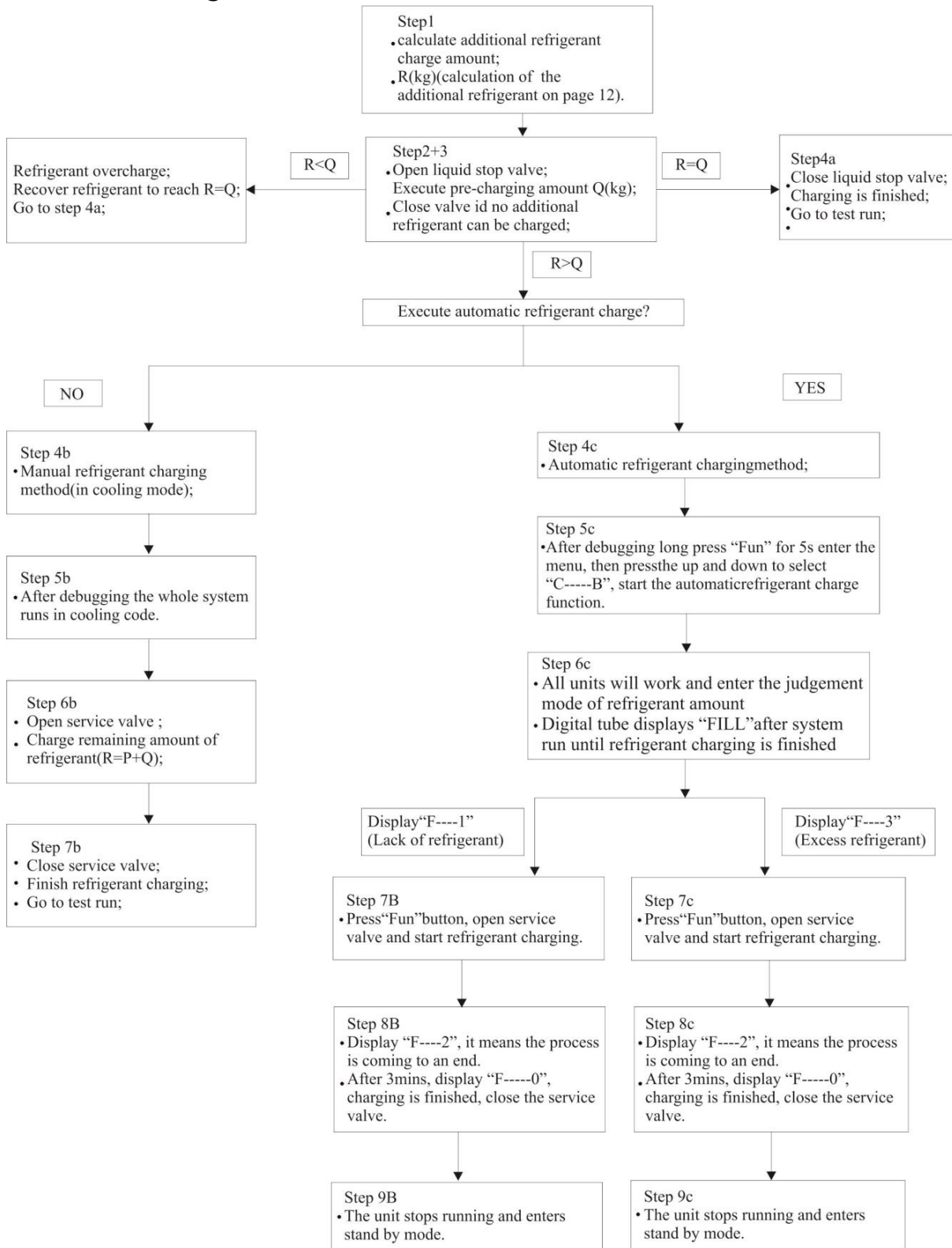

**Fault code**

Mode	Fault code	Definition of Fault Code	Fault code	Definition of Fault Code
Indoor unit	A1	Indoor ambient temperature sensor failure	A8	Indoor unit EEPROM module failure
	A2	Temperature sensor about middle position of evaporator failure	A9	The communication between indoor unit and outdoor unit failed
	A3	Indoor coil pipe inlet temperature sensor failure	AA	The communication between indoor unit and wire controller failed
	A4	Indoor coil pipe outlet temperature sensor failure	AC	Two or more indoor unit central control system address repeated
	A5	Indoor water pump failure	AE	Operation mode conflict
	A6	Failure of indoor PG fan	AH	Two or more indoor unit refrigerant system address repeated
			AJ	Indoor unit total capacity exceeded
Outdoor unit	H1	HPSa fault/Fluctuation of voltage(applicable to some models)	JJ	Indoor unit total capacity exceed
	H5	Refrigerant shortage protection	E1	The four-valve is in fault
	HJ	Missing phase or phase sequence errors in three-phase power supply	E3	DC inverter compressor 1 discharge temperature "Tda" too high shutdown protection
	HF	Low oil temperature protection	E4	DC inverter compressor 2 discharge temperature "Tda" too high shutdown protection
	C1	Environment temperature sensor Tao fault	E9	Drive refrigerant cooling pipe low temperature protection
	C2	Deforst temperature sensor Tdef fault	F1	High pressure sensor "Pd" failure
	C3	Discharge temperature of inverter compressor 1 failure	F3	High pressure sensor "Pd" protection
	C4	Discharge temperature of inverter compressor 2 failure	F4	Low pressure sensor "Pd" failure
	C6	Suction temperature of compressor failure	F6	Low pressure sensor "Pd" protection
	C9	Heat exchanger inlet Teo 1 fault	F8	Compression ratio too high protection
	CJ	Oil temperature Toila fault	F9	Compression ratio too low protection
	CC	Liquid outlet of plate heat exchanger temperature sensor fault	FH	DC inverter discharge temperature "Tda" too low shutdown protection
	CE	Gas inlet of plate heat exchanger temperature sensor fault	31	IPM module protection
	CF	Gas outlet of plate heat exchanger temperature sensor fault	32	Compressor 1 Module hardware protection

J1	The communication between ODU and ODU failed	33	Compressor 1 Module software protection
J2	Communication error between outdoor and indoor unit.	34	Compressor 1 unconnected
J3	The communication between PCB and INV module failure	35	Compressor 1 phase current overload protection
J4	The communication between main PCB and DC fan motor drive module failure	36	Compressor 1 DC bus voltage over-voltage or under-voltage failure
J5	Outdoor unit parameter setting incorrect	37	Compressor 1 temperature sensor of drive module heat fins failure
J7	Outdoor unit main control PCB ERROM module failure	38	Compressor 1 drive module high temperature limit frequency failure
39	Compressor 1 drive module high Temp. shutdown protection	54	Compressor 2 unconnected
3A	DC fan motor 1 drive module protection	55	Compressor 2 phase current overload protection
3H	DC fan motor 1 drive module start failure or Running out of step	56	Compressor 2 DC bus voltage over-voltage or under-voltage failure
3C	DC fan motor 1 drive module overcurrent protection or overcurrent sensor failure	57	Compressor 2 temperature sensor of drive module heat fins failure
3J	DC fan motor 1 drive module over-voltage or under-voltage protection	58	Compressor 2 drive module high temperature limit frequency failure
3E	Compressor 1 input current protection	59	Compressor 2 drive module high Temp. shutdown protection
3F	Compressor 1 drive module PFC protection	5A	DC fan motor 2 drive module protection
41	DC fan motor 1 drive module IPM alarm	5H	DC fan motor 2 drive module start failure or Running out of step
47	Indoor unit loss failure	5C	DC fan motor 2 drive module overcurrent protection or overcurrent sensor failure
49	DC fan motor 2 drive module IPM alarm	5J	DC fan motor 2 drive module over-voltage or under-voltage protection
51	Compressor 2 drive module IPM protection	5E	Compressor 2 input current protection
52	Compressor 2 Module hardware protection	5F	Compressor 2 drive module PFC protection
53	Compressor 2 Module software protection		

**DE-COMMISSIONING, DISMANTLING&DISPOSAL**

This product contains refrigerant under pressure, rotating parts, and electrical connections which may be a danger&cause injur.  
All work must only be carried out by competent persons using suitable protective clothing and safety precautions.



Read the Manual



Risk of Electric Shock



Unit is Remotely controlled & may start without warning



1. Isolate all sources of electrical supply to the unit including any control system supplies switched by the unit. Ensure that all points of electrical and gas isolation are secured in the OFF position. The supply cables and gas pipe work may then be disconnected and removed. For points of connection refer to unit installation instructions.
2. Remove all refrigerant from each system of the unit into a suitable container using a refrigerant reclaim or recovery unit. This refrigerant may then be reused, is appropriate, or returned to the manufacturer for disposal. Under NO circumstances should refrigerant be vented to atmosphere. Where appropriate, drain the refrigerant oil from each system into a suitable container and dispose of according to local laws and regulations governing disposal of oily wastes.
3. Packaged units can generally be removed in one piece after disconnection as above. Any fixing down bolts should be removed and then unit lifted from position using the points provided and equipment of adequate lifting capacity. Reference MUST be made to the unit installation instructions for unit weight and correct methods of lifting. Note that any residual or spilt refrigerant oil should be mopped up and disposed of as described above.
4. After removal from position the unit parts may be disposed of according to local laws and regulations.
5. Meaning of crossed Out wheeled dustbin: Do not dispose of electrical appliances as unsorted municipal waste, use separate collection facilities. Contact your local government for information regarding the collection systems available. If electrical appliances are disposed of in landfills or dumps, hazardous substances can leak into the groundwater and get into the food chain, damaging your health and well-being. When replacing old appliances with new ones, the retailer is legally obligated to take back your old appliance for disposals at least free of charge.

